

2024/25

TECHNIKA DROGOWA

PRODUCT CATALOGUE

KATALOG PRODUKTÓW

 **van berde**

WWW.VANBERDE.COM.PL

2024/25

TECHNIKA DROGOWA

PRODUCT CATALOGUE

KATALOG PRODUKTÓW

20 lat
na rynku

vb traffic

WWW.VBTRAFFIC.COM

20 lat
na rynku





KATALOG PRODUKTÓW

PRODUCT CATALOGUE

2024/25

●
SIEDZIBA GŁÓWNA POLSKA
HEADQUARTERS POLAND

VAN BERDE – ZUBIEL, POGODA
SPÓŁKA KOMANDYTOWA
Tuszów Narodowy 397,
39-332 Tuszów Narodowy
Armii Krajowej 10,
63-900 Rawicz

●
ODDZIAŁ LITWA
BRANCH LITHUANIA

UAB "VAN BERDE KAUNAS"
Taikos pr.135, KAUNAS
Lithuania
Tel.: +370 68731070
info@vanberdekaunas.lt

●
ODDZIAŁ CHORWACJA
BRANCH CROATIAN

SIGNALIZACIJA I OPREMA D.O.O.
Nova Vas 102
52474 Brtonigla - Hrvatska
tel.: +385 (0)95 398 6966
info@sio.hr

●
ODDZIAŁ CZECHY
BRANCH ČESKÁ REPUBLIKA

VBT HOLECZECH s.r.o.
Za Mlýnem 1396
696 02 Ratíškovice
+420 721 862 685
Czech Republic/Czechy
www.holeczech.cz
info@holeczech.cz

●
ODDZIAŁ UKRAINA
BRANCH UKRAINE

VAN BERDE UKRAINA
Dubrovytska St, 28, Ofis 402,
Kyiv, Ukraine, 04114
+38 (093) 371-62-31
vanberde.ukr@gmail.com

●
ODDZIAŁ RUMUNIA
BRANCH ROMANIA

VAN BERDE RUMUNIA
nr.435, jud.Satu Mare,
447135, Foieni, România
+40758072586 / +40744669962
contact@vanberde.ro
vanberde.ro

JESTEŚMY NA RYNKU
od 2005 roku



PL GRUPA VAN BERDE TO ROZPOZNAWALNA MARKA W BRANŻY DROGOWNICTWA, STAWIAJĄCA NA JAKOŚĆ I EKOLOGICZNE ROZWIĄZANIA. DZIŚ VAN BERDE DOSTARCZA GOTOWE PRODUKTY DO ZABEZPIECZANIA ROBÓT DROGOWYCH I POPRAWY BEZPIECZEŃSTWA NA DROGACH NIE TYLKO W POLSCE, ALE TEŻ W EUROPIE WSCHODNIEJ I ŚRODKOWEJ.

Siedziba firmy, działającej od 2005 r., znajduje się w Polsce w Tuszowie Narodowym. Tam też jest główny magazyn Van Berde. To centrum zarządzania wybudowane jest przy głównej trasie w pobliżu przecięcia głównych korytarzy transportowych. Takie położenie ma wielki atut w kwestii dostarczania i odbierania towaru z magazynu.

Ponadto firma Van Berde korzysta z odnawialnych źródeł energii. Panele fotowoltaiczne zasilają budynki w prąd, a pompa ciepła ogrzewa wodę i reguluje temperaturę wewnątrz biur i hal magazynowych.

Ekologia widoczna jest też w całym procesie produkcji podstaw pod znaki drogowe, na bazie recyklatu gumowego i tworzywowego. Produkcja podstaw drogowych zapoczątkowała rozwój całej gamy wyrobów bezpieczeństwa ruchu drogowego w zakładach grupy Van Berde.

Obecnie wytwarzanych jest 30 podstaw – różnych pod względem rodzaju, wagi i przeznaczenia. Roczna sprzedaż tego produktu sięga blisko miliona sztuk (tj. 20 000 ton przemiałów tworzyw sztucznych i gumy). Produkcja odbywa się w Polsce i Europie, z wykorzystaniem najwyższej jakości techniki, w oparciu o zrównoważony rozwój. Elementy gumowe powstają z materiału uzyskanego w procesie recyklingu.

Nasza pełna oferta to ponad 300 pozycji, na które składają się: progi zwalniające, progi kablowe, separatory parkingowe, azyle, znaki i bariery zabezpieczające roboty drogowe.

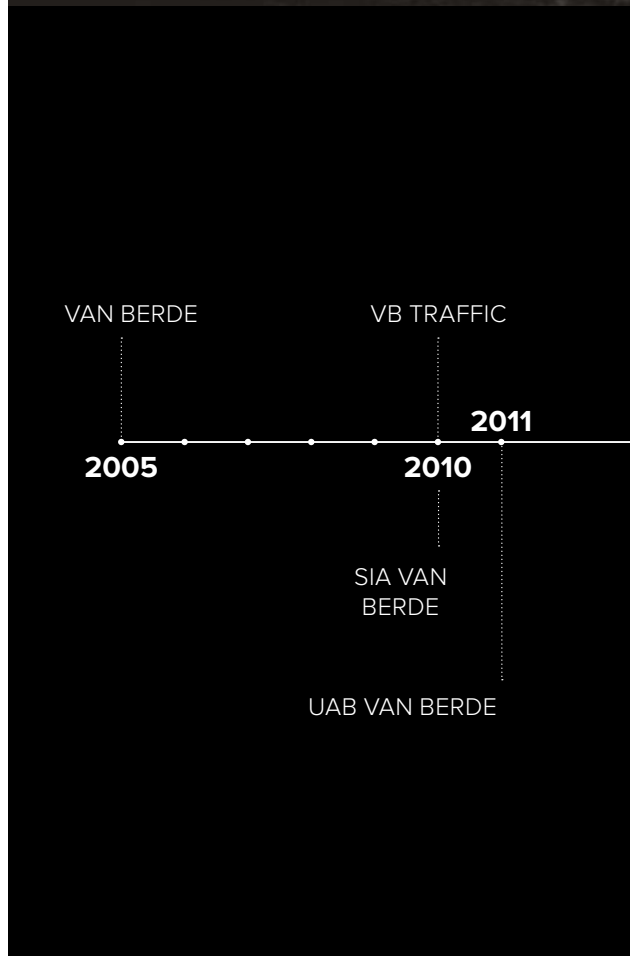

ENG THE VAN BERDE GROUP IS A RENOWNED BRAND IN THE ROAD CONSTRUCTION INDUSTRY, COMMITTED TO QUALITY AND ECOLOGICAL SOLUTIONS. TODAY, VAN BERDE SUPPLIES FINISHED PRODUCTS FOR SECURING ROADWORKS AND IMPROVING ROAD SAFETY NOT ONLY IN POLAND, BUT ALSO IN EASTERN AND CENTRAL EUROPE.

The head office of the company, which has been operating since 2005, is located in Tuszów Narodowy, Poland. The main Van Berde warehouse is also located there. This management centre is built on a main road near the intersection of major transport corridors. Such a location is a great advantage in terms of delivering and receiving products from the warehouse.

In addition, Van Berde uses renewable energy sources. Photovoltaic panels supply electricity to the buildings, while a heat pump heats the water and regulates the temperature inside the offices and warehouse halls. Ecological approach is also noticeable in the entire production process of traffic sign bases which are made from recycled rubber and plastic. The production of traffic sign bases marked the start of the development of the entire range of road safety products at the Van Berde Group's facilities.

Currently, 30 bases are produced - varying in type, weight and purpose. Annual sales of this product reach close to one million units (that is 20,000 tonnes of plastic and rubber milling). Production is done in Poland and Europe, using the high end technology, based on sustainable development.

Our full range consists of over 300 items, such as speed bumps, cable protector ramps, parking separators, pedestrian islands, signs and barriers to protect roadworks.



NAGRODA
DIAMENTY
FORBESA



PRZEDSIĘBIORSTWO
FAIR PLAY

vb traffic



PL **Własna spółka handlowa zwiększająca ofertę produktową**

Prócz typowej produkcji, w celu kompleksowej obsługi klienta, w 2010 r. powstała nowa spółka handlowa VB Traffic Sp. z o.o. jej zadaniem jest uzupełnienie oferty produkcyjnej Van Berde. Tak więc pojawiły się w ofercie lustra drogowe, lampy, aktywne przejścia dla pieszych, baterie, sygnalizacje tymczasowe i wiele innego rodzaju sprzętów typowo związanych z zabezpieczeniem robót drogowych. Ponadto wiele elementów elektrycznych VB Traffic posiada ekologiczne rozwiązania, takie jak zasilanie fotowoltaiczne, co zmniejsza emisję CO₂, a podnosi świadomość użytkowników o odnawialnych źródłach energii i możliwościach ich zastosowania.

ENG **Own growing trading company product offer**

In addition to typical production, a new trading company, VB Traffic Sp. z o.o., was established in 2010 to provide a comprehensive service to customers, its task being to complement Van Berde's production range. Thus, road mirrors, lamps, active pedestrian crossings, batteries, temporary traffic lights and many other types of equipment typically associated with securing roadworks have appeared in the range. In addition, many of VB Traffic's electrical components have environmentally friendly solutions such as photovoltaic power which reduces CO₂ emissions and raises awareness among users about renewable energy sources and their potential.

van berde group®

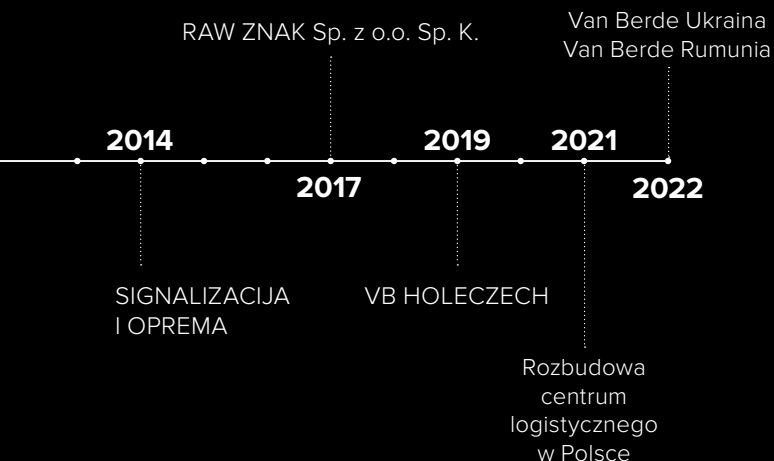

PL **Firma Van Berde miała i ma aspiracje rozszerzać swój zasięg w Europie.**

Od 2010 r. zaczęła dynamicznie się rozbudowywać o kolejne oddziały. W 2010 r. powstało SIA Van Berde, oddział łotewski, rok później UAB Van Berde Kaunas na Litwie – gdzie produkowane są elementy z tworzywa sztucznego, a w 2014 r. Signalizacja i Oprema Chorwacja. Aby wypełnić zasięg w Europie środkowej i wschodniej w 2019 r. powstał VBT Holeczech w Czechach, a w 2022 r. Van Berde Ukraina i Van Berde Rumunia dopełniając funkcję lidera grupy Van Berde jako dostawcy elementów wykorzystywanych w drogownictwie.

Wszystkie elementy bezpieczeństwa ruchu drogowego posiadają oceny techniczne wymagane prawem polskim. Natomiast elektroniczne wyroby posiadają certyfikaty CE i EN.

Już teraz **70 % sprzedaży firmy to eksport**, co jest pokłosiem współpracy z największymi firmami z branży budownictwa drogowego w całej Europie.

ENG **Van Berde had and has aspirations to expand its reach in Europe.**

Since 2010, it has begun a dynamic expansion with the addition of more branches. In 2010, SIA Van Berde, the Latvian branch, was established and, a year later, UAB Van Berde Kaunas in Lithuania - where plastic components are produced. In 2014 Signalisation and Oprema Croatia was created. To cover the Central and Eastern European market, VBT Holeczech in the Czech Republic was established in 2019 and in 2022 Van Berde Ukraine and Van Berde Romania that completed the leadership function of the Van Berde Group as a supplier of components used in road construction.

All road safety elements have the technical assessments required by Polish law. Electronic products, on the other hand, are **CE and EN certified**.

Already **70 % of the company's sales are exports**, which is a result of cooperation with major road construction companies throughout Europe.



NAGRODA WYSOKI POZIOM za produkt SALAMANDRA



PODKARPACKA NAGRODA GOSPODARCZA

www.vanberde.com.pl

OFERTA PRODUKTOWA

RANGE OF PRODUCTS

SPIS TREŚCI | INDEX

08 - 015 **PODSTAWY
ZNAKÓW DROGOWYCH**
ROAD SIGN FOOTING



016 - 023 **PROGI ZWALNIAJĄCE**
SPEED RETARDERS



024 - 029 **PROGI KABLOWE**
CABLE PROTECTORS



030 - 037 **SEPARATORY**
SEPARATORS



038 - 043 **PACHOLKI DROGOWE
I ZNAKI**
CONES AND SIGNS



044 - 051 **SŁUPKI**
POSTS



052 - 057 **BARIERY DROGOWE**
ROAD BARRIERS



OPISY IKON | ICON DESCRIPTIONS



WYMIAR
dimensions



ZESTAW MONTAŻOWY
assembly kit



PANEL FOTOWOLTAICZNY
photovoltaic panel



TEMPERATURA
temperature



WIELKOŚĆ OTWORU
hole size



ŹRÓDŁO ŚWIATŁA
light source



KOLOR ŚWIECENIA
color of light



WYSOKOŚĆ NAD JEZDNIĄ
height above the road



ŚREDNICA
diameter



ZASILANIE
power supply



RADAR
radar



NACISK
pressure



WAGA
weight



TYP BATERII
battery type



WYSOKOŚĆ LITER
height of letters



DOPUSZCZONE DO RUCHU
put into service



ILOŚĆ ŚRUB DO MONTAŻU
number of screws for assembly
dimensions



WŁĄCZNIK
switch



ZAKRES CZASOWY
time range



ZAKRES CZASOWY
time range

058 - 065 LAMPY DROGOWE
ROAD LAMPS



066 - 071 PANELE LED I LAMPY
OSTRZEGAWCZE
LED OPTICS AND
WARNING LIGHTS



072 - 079 SYGNALIZACJA
TYMCZASOWA
I ZNAKI AKTYWNE
TEMPORARY
SIGNALIZATION AND
ACTIVE SIGNSWARNING
LIGHTS



080 - 085 NAJEZDNIOWE ELEMENTY
ODBLASKOWE
ROAD STUDS



086 - 090 LUSTRA DROGOWE
ROAD MIRRORS



Zdjęcia produktów są poglądowe. Rozmiary produktów mogą się różnić.
Product images are for illustrative purposes only. The actual products appearance and size can differ a bit.

 WIELKOŚĆ OTWORU DO
MONTAŻU
hole size for assembly

 ILOŚĆ W KARTONIE
quantity in a box

 DIODA ŚWIECĄCA
light-emitting diode

 REDUKCJA MOCY
power reduction

 SZEROKOŚĆ PROMIENIA
radius width

 CERTYFIKAT
certificate

 AKUMULATOR
battery

 ZEGAR KWARCOWY
quartz clock

 POBÓR PRĄDU
power consumption

 SENSOR ZMIERZCHOWY
twilight sensor

 ZASILANIE BUFOROWE
buffer power supply

 KURTYNOWY CZUJNIK
RUCHU
curtain motion sensor

 ZAKRES WYKRYWANIA
PRĘDKOŚCI
speed detection range

 KLASA JASNOŚCI
brightness class

 ZASILANIE Z SIECI
mains power supply

 ILOŚĆ NA PALETCE EU
quantity on the EU pallet

 DOKŁADNOŚĆ
accuracy

 CZĘSTOTLIWOŚĆ DZIAŁANIA
frequency of operation

 ZASIĘG CZUJNIKA
sensor range

L/R LEWY/PRAWY
left/right



PODSTAWY DO ZNAKÓW DROGOWYCH

ROAD SIGN BASES



PL Wśród produkowanych przez Van Berde podstaw drogowych występuje duża różnorodność pod względem ich przeznaczenia, wagi i rodzajów materiałów wykorzystywanych do ich wytwarzania.

Podstawy drogowe przeznaczone są głównie do stabilizacji barier, znaków U-21, U-6, słupków U-12b oraz wielu innych produktów z kategorii ZNAKI czy SŁUPKI.

Najsolidniejsze podstawy wykonane są z gumy, a ten trwały materiał, z którego są produkowane powstaje w procesie recyklingu. Przemiał zużytych opon i innych gumowych elementów pozwala w dalszym procesie produkcji na uzyskanie pełnowartościowego produktu, który wyróżnia się dużą wytrzymałością. Recykling jest też główną składową w produkcji podstaw z PVC. Ekologiczny aspekt wytwarzania podstaw w fabrykach w Polsce jest zgodny z zakładową kontrolą jakości.

Podstawy dające największą stabilność, dedykowane są do zabezpieczania prac w ruchu pozamiejskim.

Są to modele o największej wadze 28-25 kg i wykonane są z gumy lub PVC. Można w nich zamocować znak lub barierę bez obaw, że pod wpływem naporu powietrza samochodów jadących z dużą prędkością, przewrócą się.

Natomiast lżejsze podstawy, z tworzywa sztucznego, doskonale sprawdzają się w tymczasowym wykorzystaniu podczas zabezpieczania robót drogowych w terenie zabudowanym.

Większość podstaw w spodniej części ma stopki, co utrudnia ich przesuwanie względem podłoża, a otwory i wpusty pozwalają na ich bezpieczne składowanie.

W całej gamie podstaw z gumy wyróżnia się WIVA, która wraz z elastycznym znakiem U-21 tworzy nowatorski system WIVA, wykorzystywany do zabezpieczania robót drogowych. System gwarantuje trwałość i odporność na warunki atmosferyczne oraz uderzenia. Panel jest zapinany w podstawie specjalnym zamkiem, który uniemożliwia jego wypadanie. W podstawie jest też otwór do umieszczenia klasycznego znaku U-21 z trzpieniem o wymiarach 60x60 mm. Spodnia część podstawy WIVA wyposażona jest w specjalne przyssawki zapobiegające jej przesuwaniu. Całość waży 17 kg. Jest to nowatorskie rozwiązanie na polskim rynku opatentowane przez firmę Van Berde pod nr ZWW 001128375-0001.

Wiele podstaw produkowanych jest też na indywidualne zamówienia klientów.

ENG Among the road bases produced by Van Berde there is a wide variety in terms of their purpose, weight and types of materials used in their production.

The road bases are intended mainly for stabilizing of barriers, U-21 and U-6 signs, U-12b posts and many other products from the SIGNS or POSTS category.

The sturdiest bases are made of durable rubber material, which is obtained in the recycling process. Further grinding of used tires and other rubber elements results in a full-value and highly durable product. Recycling is also a major part in the production process of PVC bases. The ecological aspects of production in polish factories comply with in-house quality control.

Bases providing the greatest stability are dedicated to securing works in rural traffic.

These models are made of rubber or PVC and have maximum weight of 28-25 kg. You can attach a road delineator or a barrier to them without worrying about tipping over under air pressure from cars traveling at high speeds. On the other hand, lighter plastic bases are perfect for temporary use when securing road works in urban areas. Most bases have feet on the underside, which makes signs difficult to push across the ground, and the holes and inlets enable safe storage.

WIVA stands out from the entire range of rubber bases. Together with the flexible U-21 sign they comprise the innovative WIVA system for securing road works. The system guarantees durability and resistance to weather conditions and impacts. The panel is fastened at the base with a special lock that prevents it from falling out. There is also a hole in the base for the classic U-21 sign with a 60x60mm spindle. The underside of the WIVA base is equipped with special suction cups to prevent it from moving. The whole package weighs 17 kg. It is an innovative solution on the Polish market, patented by Van Berde under the number ZWW 001128375-0001.

Many bases are also produced for individual customer orders.



Podstawa gumowa P001/P006

Rubber base P001/P006

CODE

09-0001-01
09-0006-01



25 kg



45 szt./pcs

P006

P001

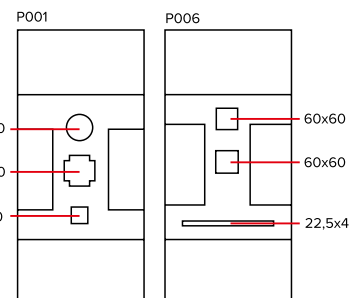
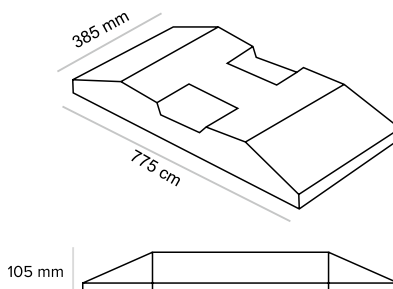

Podstawa gumowa P002

Rubber base P002

CODE

09-0002-01



20 kg



50 szt./pcs

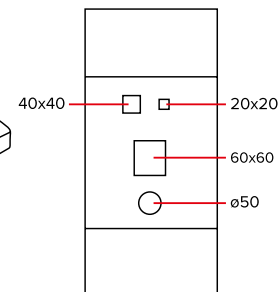
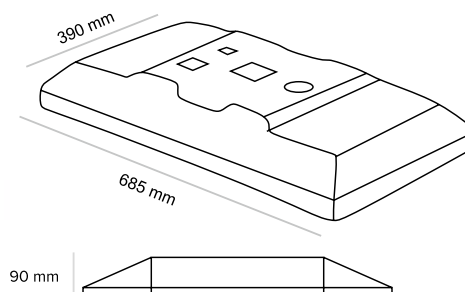

Podstawa PVC P011/P012

PVC base P011/P012

CODE

09-0011-02
09-0012-02



25 kg
24 kg



30 szt./pcs
30 szt./pcs

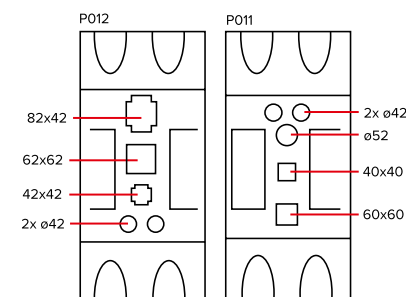
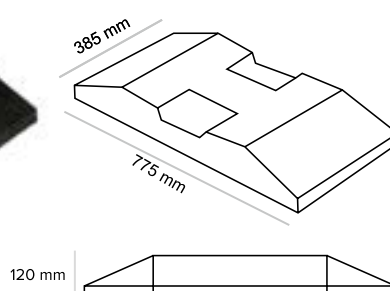

Podstawa PVC P028

PVC base P028

CODE

09-0028-01



25 kg



30 szt./pcs

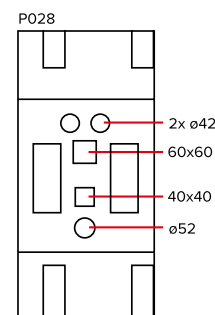
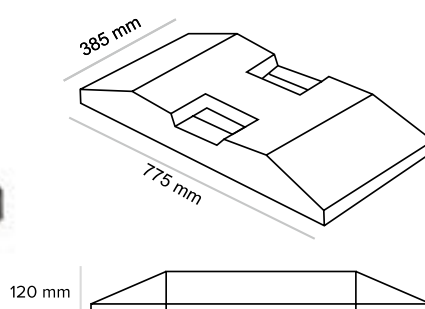

Podstawa dostępna na zamówienie z logo i dostosowanymi otworami.
Base available on request with logo and customized openings.



Podstawa PVC P010
PVC base P010

CODE

09-0010-02



15 kg



60 szt./pcs

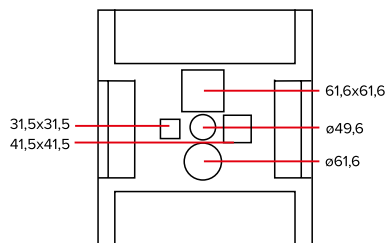
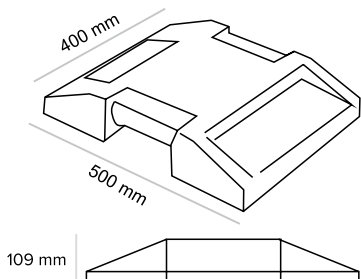

Podstawa PVC P016
PVC base P016

CODE

09-0016-02



15,5 kg



60 szt./pcs

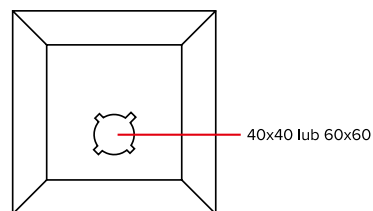
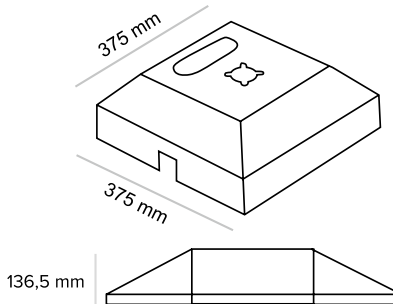

Podstawa PVC P017
PVC base P017

CODE

09-0017-02



11 kg



60 szt./pcs

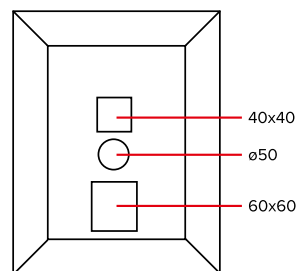
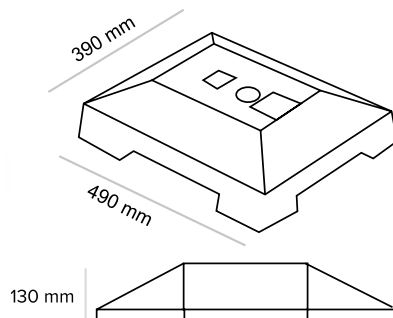

Podstawa dostępna na zamówienie z logo i dostosowanymi otworami.
Base available on request with logo and customized openings.



Podstawa PVC P018
PVC base P018

CODE

09-0018-02



16 kg



40 szt./pcs

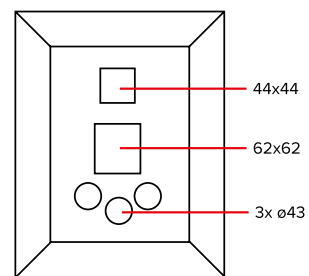
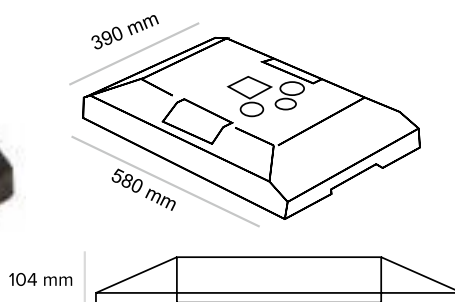

NEW Podstawa PVC P031
PVC base P031

CODE

09-0031-02



28 kg



33 szt./pcs

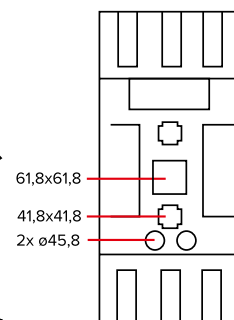
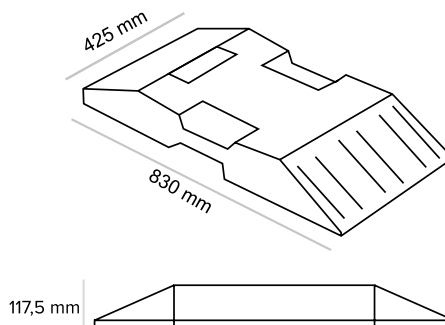

Podstawa PVC P026 FR
PVC base P026 FR

CODE

09-0266-02



24 kg



30 szt./pcs

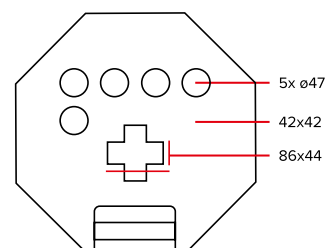
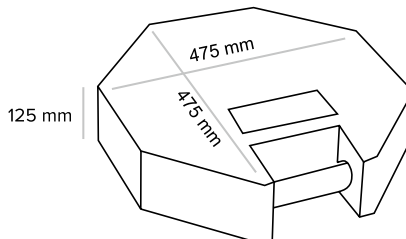

Podstawa dostępna na zamówienie z logo i dostosowanymi otworami.
Base available on request with logo and customized openings.



Podstawa gumowa P004
Rubber base P004

CODE

09-0004-01



14 kg



50 szt./pcs

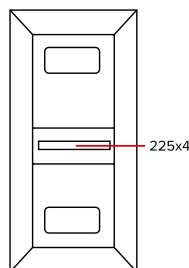
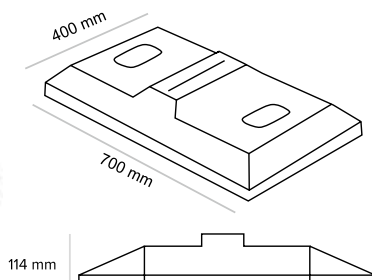

11-5003-02 ZNAK SKANDYNAWSKI



WIVA®
Podstawa gumowa WIVA
Rubber base WIVA

CODE

09-0020-01



15 kg



50 szt./pcs

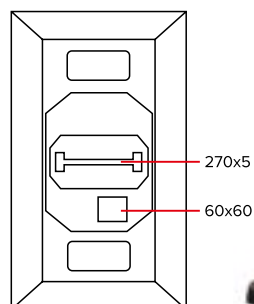
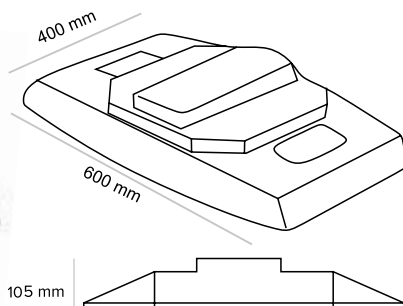

11-500501 ZNAK WIVA

Podstawa PVC P014
PVC base P014

CODE

09-0014-02



22 kg



50 szt./pcs

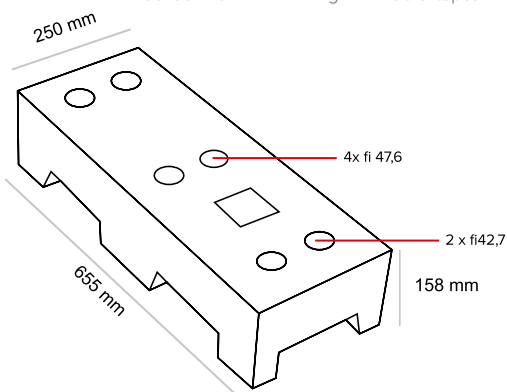

PVC P014/ PVC P023

NEW **Podstawa PVC P023**
PVC base P023

CODE

09-0023-02



16,5 / 18 kg

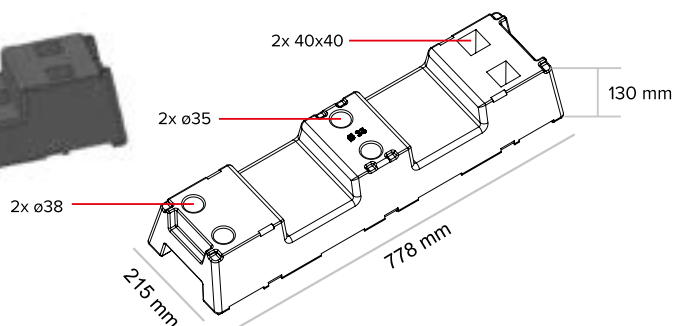

07-2000-03
ZAPORA DROGOWA U-20VB TRAFFIC



Podstawa PVC P015
PVC base P015

CODE

09-0015-02



15 kg



60 szt./pcs

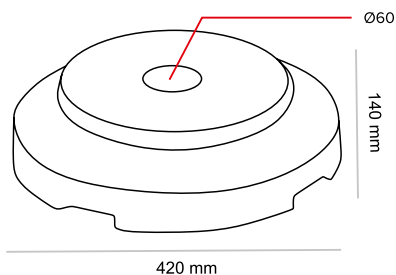

11-1000-02 SŁUPEK U-12B

Podstawa gumowa P008/P009
Rubber base P008/P009

CODE

09-0008-01



7 kg



100 szt./pcs

09-0009-01

7 kg

100 szt./pcs

P008

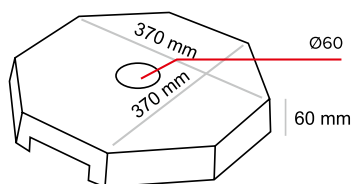

11-1000-01 SŁUPEK U-12B

P009

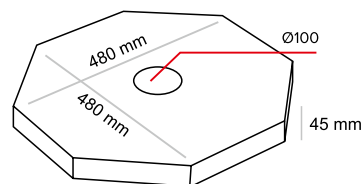

11-8001-01 SŁUPEK FI 100

Podstawa gumowa P003
Rubber base P003

CODE

09-0003-01



6,5 kg



108 szt./pcs

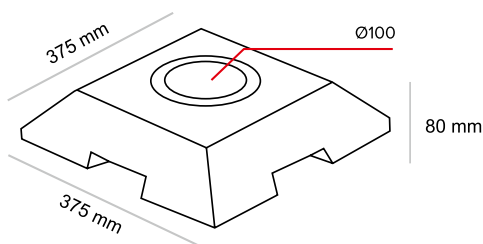

11-8001-01 SŁUPEK FI 100

Podstawa PVC P026
PVC base P026

CODE

09-0026-02



24 kg



30 szt./pcs

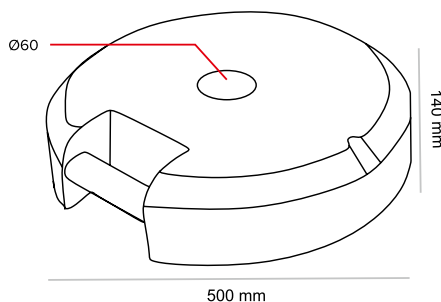

07-2000-03
ZAPORA DROGOWA U-20VB
TRAFFIC



Podstawa gumowa P027
Rubber base P027

CODE

09-0027-01



26 kg



10 szt./pcs

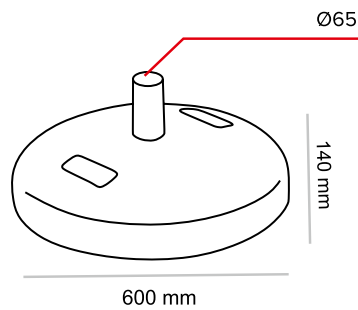

Podstawa gumowa U-12C
Rubber base U-12C

CODE

09-2001-01



1,4 kg



300 szt./pcs



x3

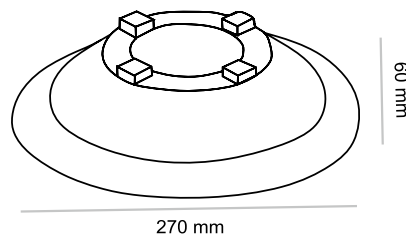

Podstawa PVC U-3
PVC base U-3

CODE

09-2003-02



3 kg



300 szt./pcs

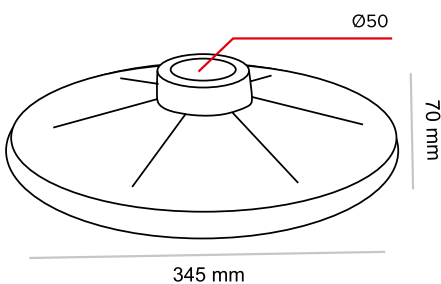



PROGI PODRZUTOWE I ZWALNIAJĄCE

SPEED RETARDERS





PL Progi zwalniające są sztandarowym wyrobem Van Berde. Bogatą gamę progów zwalniających dzielimy w zależności od sposobu instalacji oraz zastosowania na listwowe i wyspowe oraz zwalniające i podrzutowe.

Progi w większości wykonane są z gumy, którą pozyskuje się w procesie recyklingu zużytych opon i innych wyrobów gumowych. Produkcja odbywa się w Polsce i innych krajach europejskich z zachowaniem najwyższych standardów.

Wszystkie progi są poddawane Krajowej Ocenie Technicznej. Każdy z produktów posiada wymagane badania i dokumenty potwierdzające wysokie parametry techniczne. Kompletnie dokumenty niezbędne w prawie polskim dają gwarancję wieloletniego użytkowania. Każdy kupujący może pobrać dokumentację produktową ze strony internetowej naszej firmy. Dobrze wyprofilowane progi, posiadają elementy odblaskowe zwiększające ich widoczność. Służą do tego taśma odblaskowa lub specjalne szklane oczka. Każdy z progów ma dużą wytrzymałość zgodnie z przeznaczeniem w ruchu miejskim.

Niektóre z progów można dodatkowo ustabilizować na etapie montowania do twardego podłoża za pomocą kołków. Takim wyrobem jest gumowy próg podrzutowy SALAMANDRA (PpVB-5/42), który jest produktem opatentowanym przez Van Berde. Próg ma bardzo dużą wytrzymałość na nacisk samochodów ciężarowych.

Ten specjalnie zaprojektowany próg, jest wykonywany z najwyższej jakości mieszanki gumowej, która charakteryzuje się wyjątkową wytrzymałością i elastycznością jest w stanie dopasować się do nierównej nawierzchni. Powierzchnia progów jest tak zaprojektowana, aby w czasie deszczu system kanałów oczyszczał powierzchnię. Zakończenia progów to odrębny element bezpieczeństwa ruchu, tzw. próg punktowy.

Próg w bocznej części wyposażony jest w element łączący, tzw. „PUZEL”. Łączy on stabilnie elementy progów i jest pomocny przy wykorzystaniu progów tymczasowo, np. przy przeprowadzaniu przewodów elektrycznych na budowach, koncertach, targach. Montaż progów odbywa się poprzez 4 otwory montażowe. W każdym z nich zostały zatopione ocynkowane wkładki stabilizujące, co jest dodatkowym wzmocnieniem. Cały system kanałów w spodniej części progów zapobiega ich przesuwaniu się oraz unoszeniu elementów przez zamarzającą wodę.

ENG Speed bumps are Van Berde's flagship product. The wide range of speed bumps is divided depending on installation method (into speed humps and speed cushions) and on their use (speed ramps and speed breakers).

The bumps are mostly made of rubber, which is obtained in the process of recycling used tires and other rubber products. Production takes place in Poland and Europe with the highest standards.

All bumps are subject to the National Technical Assessment. Each product passed required tests and has documents confirming high technical parameters. The full documentation required by the Polish law guarantees long-standing use. Each buyer can download product documentation from our company's website. Well-profiled bumps have reflective elements that increase their visibility, either reflective tape or special glass eyelets. Each bump is characterized by high durability, which is a requirement for urban traffic.

Some bumps can be additionally stabilized during assembly by use of expansion bolts. This includes a product patented by Van Berde, the SALAMANDRA rubber speed ramp (PpVB-5/42). The ramp has a very high resistance to pressure from trucks.

This specifically designed ramp is made of the highest quality rubber compound. It is characterized by exceptional durability and flexibility, which makes it able to adapt to uneven surfaces. The ramp surface is designed in such a way that the canal system cleans the surface when it rains. On the other hand, the ramp endings are a separate element of traffic safety, the so-called "speed bump discs".

The side of the ramp is equipped with a connecting element, the so-called „PUZEL”. It stably connects the elements of the ramp and is helpful when using it temporarily, e.g. when laying electrical cables at construction sites, concerts or fairs. The ramps are installed through 4 mounting holes. In each of them, galvanized stabilizing inserts are embedded, which provides additional reinforcement. The entire system of channels at the bottom of the ramp prevents them from shifting and lifting elements by freezing water.



SLOWLY 3



Próg podrzutowy PpVB-5/35 i PpVB-7/40 (gumowy - 5 cm i 7 cm)

Rubber speed ramp 5 cm/7 cm



	CODE	kg	
5 cm	■ 12-1034- 001 002	3,5 kg	2x
	● 12-1034- 011	1,5 kg	2x
7 cm	■ 12-1040- 001 002	4,8 kg	2x
	● 12-1040- 011	2,2 kg	2x

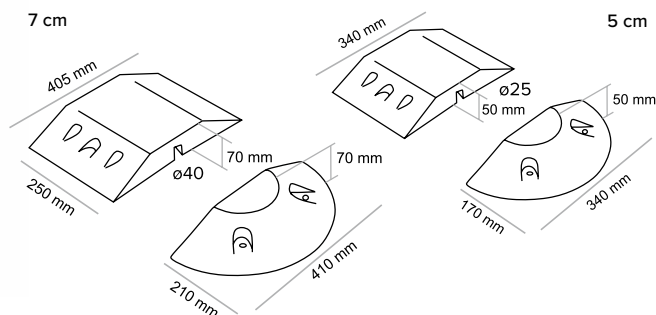

vb traffic

Próg podrzutowy PpVB-3/50 (SLOWLY 3)

Speed ramp SLOWLY 3



	CODE	kg	
■	12-1003- 001 002	6,8 kg	4x + 2x
	● 12-1003- 003 004	2,2 kg	4x + 2x

500x500x30 mm



500x250x30 mm



vb traffic

Próg podrzutowy PpVB-5/40 (SLOWLY 5)

Speed ramp SLOWLY 5



	CODE	kg	
■	12-1005- 01 02	7,5 kg	4x + 2x
	● 12-1005- 03 04	2,5 kg	4x + 2x

400x500x50 mm



400x200x50 mm





vb traffic

Próg podrzutowy SLOWLY 6

Speed ramp SLOWLY 6



CODE	Color	Weight (kg)	Quantity
12-1006- 01	Yellow	7,5 kg	4x + 2x
12-1006- 02	Black	7,5 kg	4x + 2x
12-1006- 03	Yellow	2,5 kg	4x + 2x
12-1006- 04	Black	2,5 kg	4x + 2x

400x500x50 mm



12-1006-01



12-1006-02

400x200x50 mm



12-1006-03



12-1006-04



vb traffic

Próg podrzutowy PpVB-7/50 (SLOWLY 7)

Speed ramp SLOWLY 7



CODE	Color	Weight (kg)	Quantity
12-1007- 01	Yellow	12,5 kg	4x
12-1007- 02	Black	12,5 kg	4x
12-1007- 03	Yellow	4 kg	2x
12-1007- 04	Black	4 kg	2x

500x500x70 mm



12-1007-01



12-1007-02

ø45

500x250x70 mm



12-1007-03



12-1007-04

Próg podrzutowy PpVB-5/42 (gumowy - SALAMANDRA)

Rubber speed ramp SALAMANDRA



CODE	Color	Weight (kg)	Quantity
12-1042-01	Yellow	8,5 kg	4x
12-1007- 11	Yellow	3,2 kg	3x
12-1007- 12	Black	3,2 kg	3x

420x500x50 mm



12-1007-01

ø25

420x230x50 mm



12-1042-11



12-1042-12





Gumowy-5M



MIMR 300



Próg podrzutowy PpVB-5/40 (gumowy-4M)

Rubber speed ramp PpVB-5/40

CODE

- 12-1040-01
- 12-1040-11



- 8,5 kg
- 2,3 kg



- 4x
- 3x

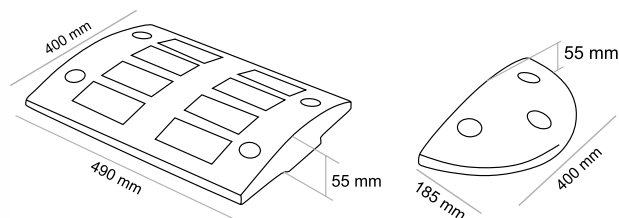

Próg podrzutowy PpVB-5/60 (gumowy-5M/3M)

Rubber speed ramp PpVB-5/60

CODE

- 3M ■ 12-1030-01
- 12-1030-11
- 5M ■ 12-1060-01
- 12-1060-11



- 9,4 kg
- 4,4 kg
- 15,5 kg
- 5,5 kg



- 4x
- 3x
- 4x
- 3x



- 3M 600x500x30 mm
- 5M 600x500x50 mm

- 3M 600x250x30 mm
- 5M 600x250x50 mm



12-1060-01



12-1060-11

Próg zwalniający PVB-5/90 i PVB-7/98 (gumowy-5D/7D)

Rubber speed ramp PVB-5/90 and PVB-7/98

CODE

- 5D ■ 12-1090-01
- 12-1090-11
- 7D ■ 12-1098-001
- 12-1098-11



- 21 kg
- 7 kg
- 23 kg
- 14,5 kg



- 4x 3x ø25mm
- 3x
- 4x 3x ø25mm
- 3x



- 5D 900x500x50 mm
- 7D 980x500x70 mm



- 5D 900x280x50 mm
- 7D 980x315x70 mm



ISLE 6

Wyspowy próg zwalniający PwVB 6/90 (ISLE 4 i ISLE 6)

Speed cushion PwVB-6/90 ISLE 4 and ISLE 6

CODE

Isle 4 12-2000-01

Isle 6 12-3000-01



192 kg

295 kg

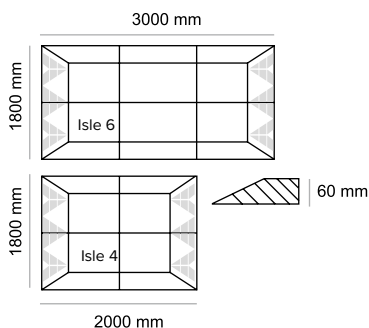

Minirondo MIMR 300 (gumowe)

Rubber roundabout MIMR 300

CODE

12-3000-30



500 kg

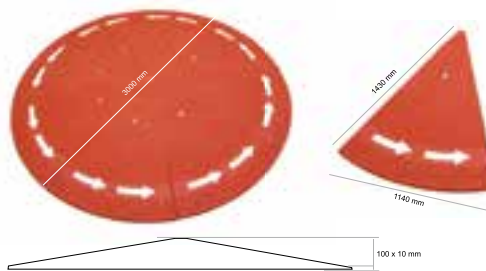

Zwijany próg podrzutowy EASYROLL

Foldable and carry speed ramp

CODE

12-3000-25



12 kg



3000x250x25 mm





NEW Próg zwalniający płytowy PzPVB
Pedestrian crossing cushion



100 mm

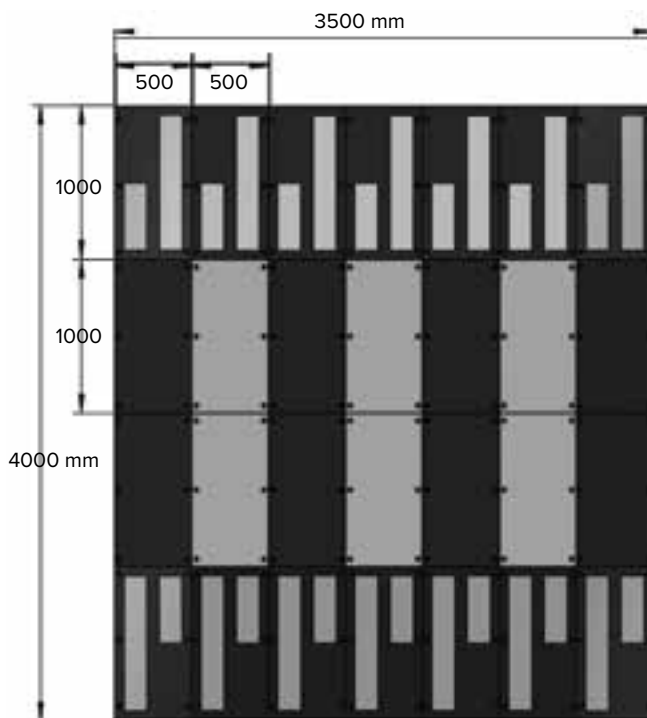

100 mm



Najzd PzPVB-10/N

End part

CODE

12-1000-01



30 kg



1000x500x100 mm



czarny- białe odblaski
black-white reflective



Najzd skrajny PzPVB-10/NS

Middle edge part

CODE

12-1000-06



32 kg



1000x500x100 mm



Element środkowy PzPVB-10/S, czarny

Middle part , black

CODE

12-1000-02



50 kg



1000x500x100 mm

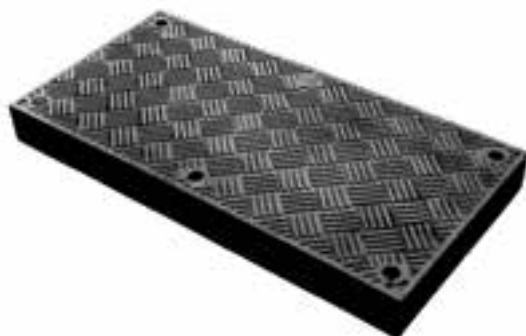

Element środkowy PzPVB-10/S, biały

Middle part , white

CODE

12-1000-03



50 kg



1000x500x100 mm



Element narożny - prawy PzPVB-10/NR

End edge part - right

CODE

12-1000-04



25 kg



1000x500x100 mm



czarny- białe odblaski
black-white reflective



Element narożny - lewy PzPVB-10/NL

End edge part - left

CODE

12-1000-05



25 kg



1000x500x100 mm



czarny- białe odblaski
black-white reflective

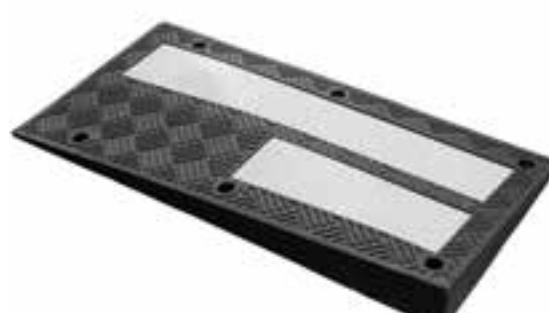

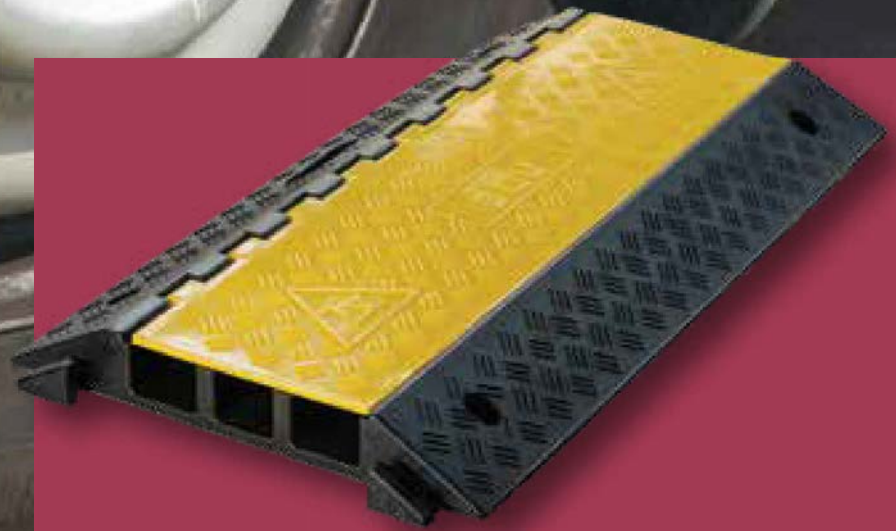

PROGI KABLOWE

CABLE PROTECTORS

PL Asortyment z kategorii progów kablowych jest bardzo skutecznym rozwiązaniem gdy zachodzi potrzeba uporządkowania, zabezpieczenia i ukrycia przewodów elektrycznych lub węży strażackich.

Wśród całej gamy wyrobów osłon kablowych, można wyróżnić te gumowe o największej wytrzymałości, które są rekomendowane do ruchu samochodów ciężarowych. Mogą po nich jeździć auta o wadze do 40 ton. Kategoria progów kablowych zawiera też przejazdy, w których umieszcza się dwa przewody o średnicy min. 7,5 cm i max. 12 cm. Te gumowe progi można ustabilizować poprzez połączenie ich metalowym elementem spinającym i dodatkowo przykręcić do podłoża. Gumowa osłona kablowa o długości 1200 mm, jest doskonała do zabezpieczania przewodów prowadzonych tymczasowo w pomieszczeniach o dużej powierzchni np. halach magazynowych lub produkcyjnych.

Kolejna gama wyrobów to tymczasowe przenośne progi kablowe z tworzywa sztucznego. Osłony kablowe, z zamykaną, górną klapą, pozwalają na poprowadzenie 2, 3 lub 5 przewodów. Dzięki dodatkowym elementom łączenia progi można ułożyć pod kątem 45 stopni, a nie tylko w prosty ciąg.

Progi kablowe można łączyć ze sobą jak puzzle dzięki specjalnym zaczepom, zaś w celu zwiększenia ich stabilności istnieje możliwość przymocowania kołkami rozporowymi do podłoża. Takie progi kablowe mogą być wykorzystywane w miejscach gdzie obowiązuje ruch pieszy lub ograniczony ruch kołowy, ponieważ wytrzymują nacisk do 9 ton.

Wszystkie produkty przeznaczone są do użytku tymczasowego.

ENG The range of cable protectors is a very effective solution when there is a need to organize, secure or hide electric wires or fire hoses.

Among the whole range of cable protectors, we can distinguish the most durable rubber ones, which are recommended for truck traffic. They can be driven over by cars weighing up to 40 tons. The category of cable protectors also includes crossings in which two wires with a diameter of at least 7.5 cm and a maximum of 12 cm are placed. These rubber bumps can be stabilized by joining them with a metal clamping element and additionally screwed to the ground. The 1200 mm long rubber cable cover is perfect for securing cables temporarily routed in rooms with a large area, e.g. warehouse or production halls. Another product range is portable plastic cable protectors for temporary use. Cable covers with a closed, top flap, allow 2, 3 or 5 cables to be routed. Thanks to additional joining elements, the protectors can be arranged at an angle of 45 degrees and not just in a straight line.

Cable protectors can be joined together like puzzles thanks to special hooks. In order to increase their stability, it is possible to attach them to the ground with expansion bolts. Such cable thresholds can be used in places where there is pedestrian traffic or limited vehicle traffic, as they can withstand a pressure of up to 9 tons.

They are all intended for temporary use.



Gumowa osłona kablowa 2-kanalowa

Rubber cable protector 2-channels

CODE

- 12-9002-01
- L 12-9002-02



5,5 kg
2 kg



30 | 32 x 32 mm

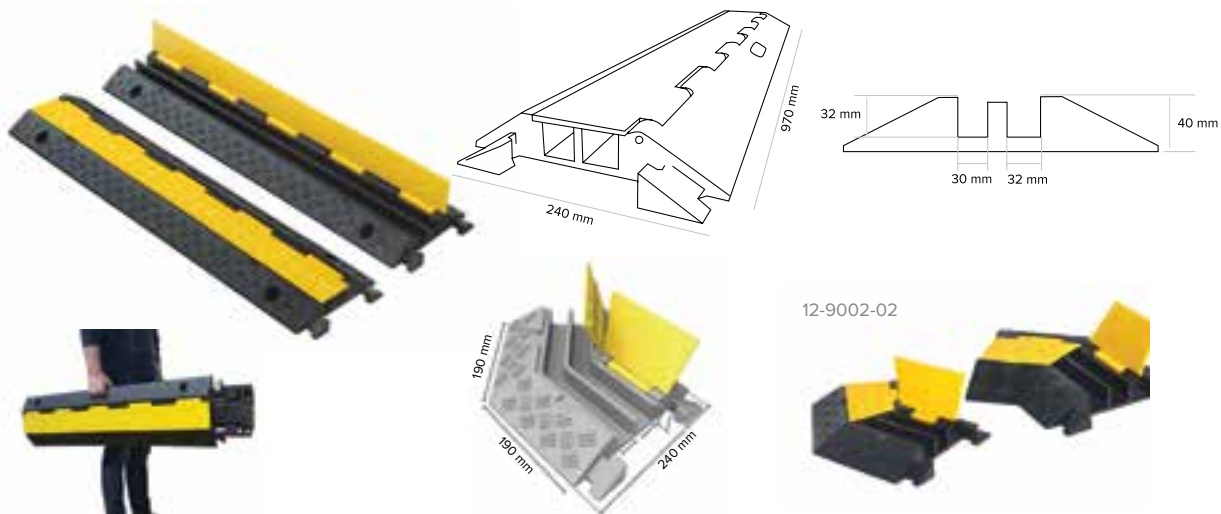

Gumowa osłona kablowa 3-kanalowa

Rubber cable protector 3-channels

CODE

- 12-9003-01
- L 12-9003-02



17 kg
7 kg



65 | 56 | 68 x 50 mm

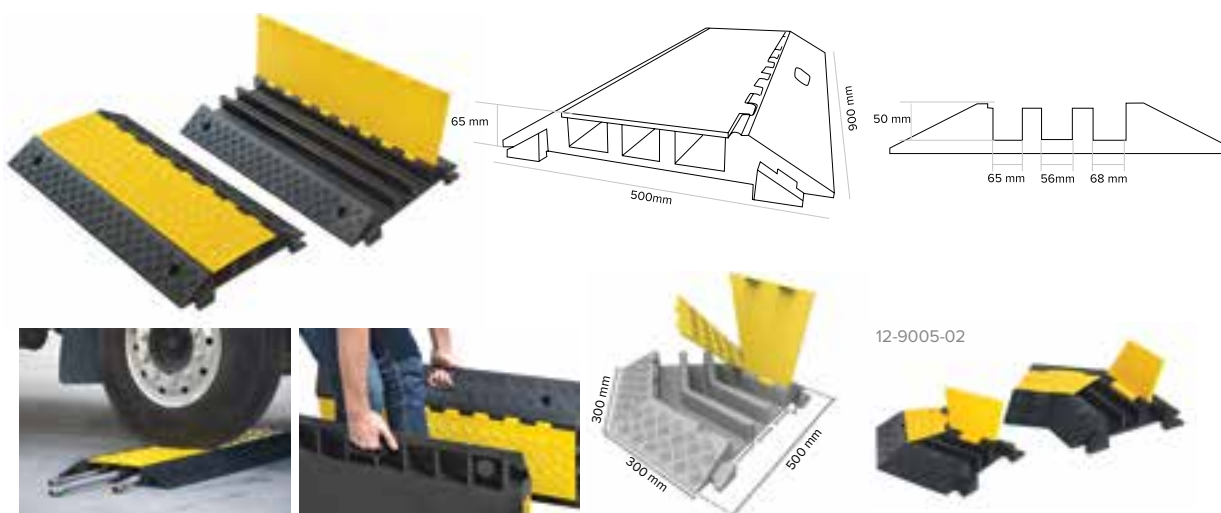

Gumowa osłona kablowa 5-kanalowa

Rubber cable protector 5-channels

CODE

- 12-9005-01
- L 12-9005-02



12,15 kg
7,8 kg



5x (38 x 35) mm

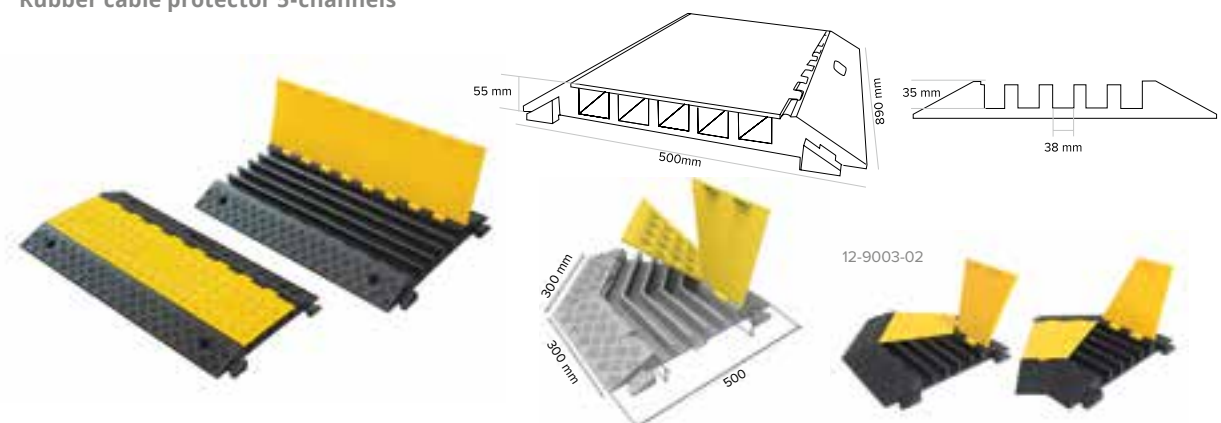

Gumowy przejazd przez rury MAX

PVC Rubber hose protector MAX

CODE

12-0855-01



9 kg



2x (90x72) mm

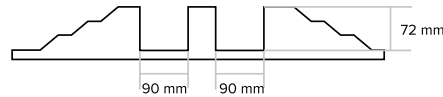
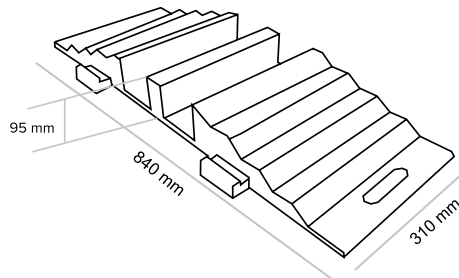

Gumowy przejazd przez rury MAX II

Rubber hose protector MAX II

CODE

12-0800-01



18,2 kg



2x (80x70) mm

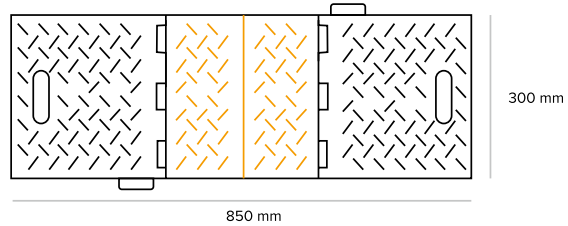
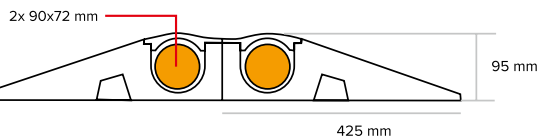

Gumowa osłona kablowa 1200

Rubber cable protector 1200

CODE

■ 12-1200-01

10 kg



1x (45x45) mm | 2x (20x20) mm

■ 12-1200-02

10 kg

1x (45x45) mm | 2x (20x20) mm

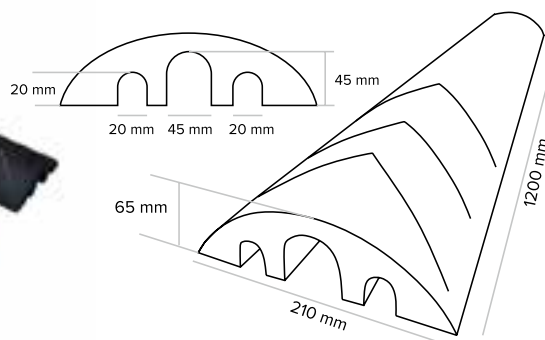



Gumowy przejazd kablowy 40 T

Heavy cable and hose protector 40 T

CODE

CODE	Ø	Icon	Weight
12-0075-02	2 x 75 mm	600x300x90 mm	9,5 kg
12-0090-02	2 x 90 mm	850x850x100 mm	15,5 kg
12-0120-02	2 x 120 mm	1000x300x135 mm	24,5 kg

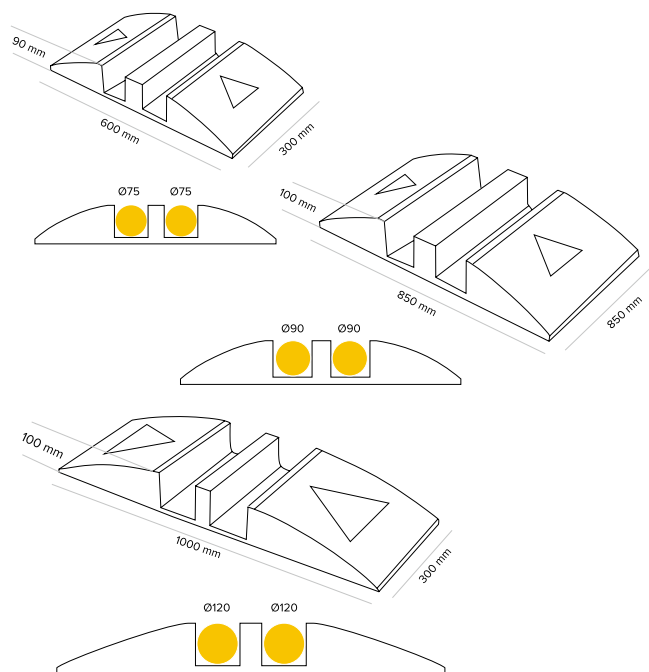

Gumowy próg kablowy 40 T

Heavy duty cable protector 40 T

CODE

CODE	Ø	Icon	Weight
12-0050-02	2 x 50 mm	500x500x80 mm	14,4 kg
12-0080-02	2 x 80 mm	500x600x113 mm	22 kg
12-0120-01	1 x 120 mm	800x800x150 mm	42 kg

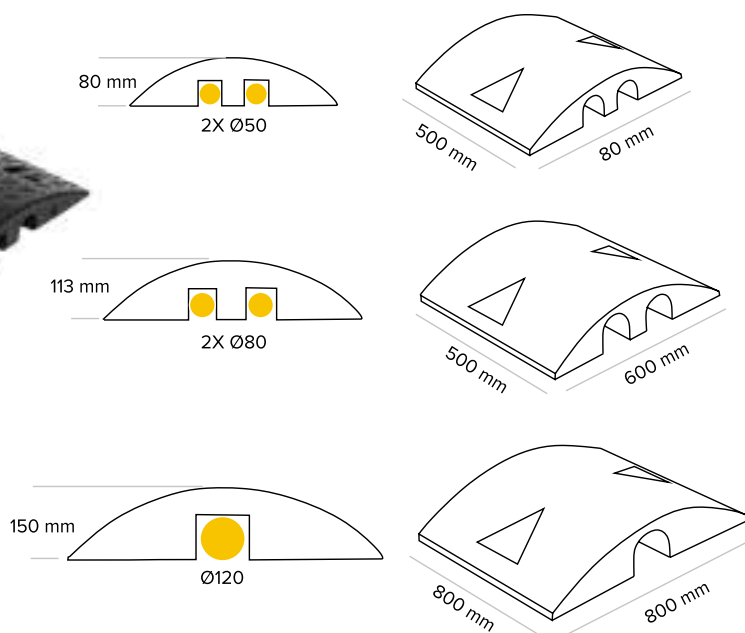

Kładka budowlana U-28
Building footbridge

CODE

12-1700-10



33 kg



1 t

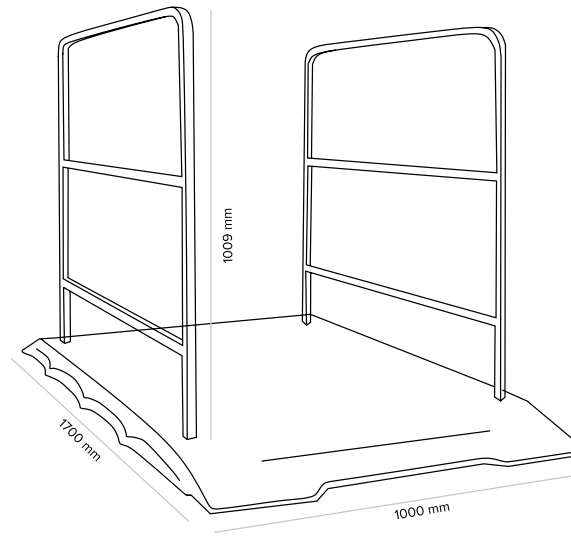



SEPARATOR I AZYLE

SEPARATORS AND TRAFFIC
ISLANDS





PL Separatory wykonywane z gumy oraz PVC są doskonałym rozwiązaniem gdy zachodzi konieczność ustawienia ogranicznika. Produkcja tej grupy wyrobów oparta jest na recyklingu gumy i tworzywa sztucznego w fabrykach w Polsce i Europie. Produkty wytwarzane są zgodnie z zakładowymi kontrolami jakości z zachowaniem najwyższych standardów.

Separatory poddawane są Krajowej Ocenie Technicznej i spełniają najwyższe normy techniczne. Kompletne dokumenty wymagane w prawie polskim są gwarancją wieloletniego użytkowania. Krajową Deklarację Właściwości Użytkowych można pobrać z naszej strony internetowej.

Cała kategoria dzieli się na separatory parkingowe, drogowe i rowerowe. Taki podział ma swoje źródło w ich przeznaczeniu.

Separatory L U-25b (guma), B U-25b i S U-25b (PVC) to idealne rozwiązanie na parkingach otwartych i zabudowanych, gdzie często występuje konieczność separacji miejsc w taki sposób, aby zminimalizować ryzyko uderzenia w ścianę lub inny pojazd. Separatory posiadają elementy odblaskowe w postaci taśmy odblaskowej lub plastikowych elementów odblaskowych. Separatory montuje się do podłoża przy użyciu kołków rozporowych.

Separatory drogowe U-25a i U-25b (PVC) są przydatne do trwałego oddzielenia pasów ruchu, buspasa lub torów tramwajowych z ciągu jezdni.

Można je też wykorzystać do tymczasowego rozdzielania pasów jezdni, dodatkowo umieszczając w nich znaki U-6. W U-25a można również umieścić szklane oczka odblaskowe.

Ostatnią grupą separatorów są separatory rowerowe wykonane z gumy zwulkanizowanej z elementami odblaskowymi z folii 3M. Te produkty dedykowane są do wydzielania ścieżek rowerowych z pasa jezdni lub z pasa ruchu pieszego.

W tej grupie znajdują się też odboje, azyle drogowe z tworzywa oraz elastyczne krawężniki, które sprawdzą się w wyznaczaniu wysepek drogowych lub rond.

ENG Separators made of rubber and PVC are a perfect solution when it is necessary to set a limiter. The production of this group of products is based on recycling rubber and plastic in factories in Poland and Europe. The products are manufactured in accordance with factory quality controls and meet the highest standards.

Separators are subject to the National Technical Assessment and are in line with the highest technical norms. Complete documents required by Polish law guarantee many years of use. The National Declaration of Performance can be downloaded from our website.

The whole category is divided into parking, road and bicycle separators. This division reflects their purpose.

The L U-25b (rubber), B U-25b and S U-25b (PVC) separators are an ideal solution for open and built-up car parks, where it is often necessary to separate places in such a way as to minimize the risk of hitting a wall or another vehicle. The separators have reflective elements such as reflective tape or plastic elements. Separators are fixed to the ground by use of expansion bolts.

U-25a and U-25b (PVC) road separators are useful for permanent separation of traffic lanes, bus lanes or tram tracks from the roadway.

They can also be used for temporary separation of road lanes by placing U-6 signs inside them. The U-25a can also be fitted with reflective glass eyelets.

This group also includes bumpers, plastic road sanctuaries and flexible curbs that will work well in marking traffic islands or roundabouts.



U-25b, VB PS-I



U-25b, VB PS-I



Separator parkingowy U-25b 550

Rubber parking separator U-25b 550

CODE



10-0560- 01 02 5 kg

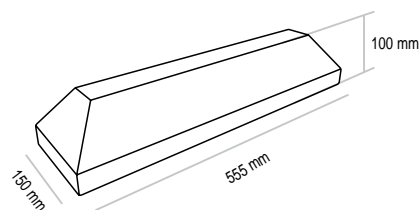

Separator parkingowy U-25b 900

Rubber parking separator U-25b 900

CODE



10-0900- 01 02 8 kg

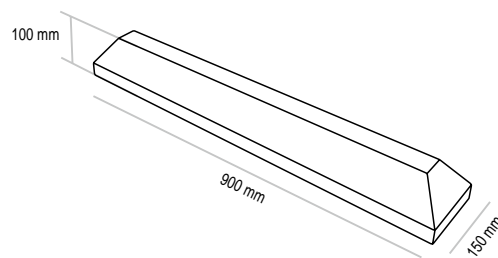

Separator parkingowy U-25b 1200

Rubber parking separator U-25b 1200

CODE



10-1200- 01 02 11 kg

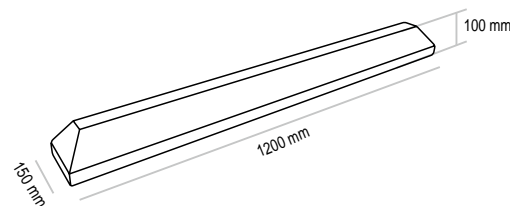



U-25b, VB PS-I



TIR – PARKSTOP

Separator ruchu punktowy parkingowy U-25b, VB PS-I (gumowy-długi)

Rubber parking separator U-25b, VB PS-I

CODE    
10-1076- 01 02 16 kg 5x

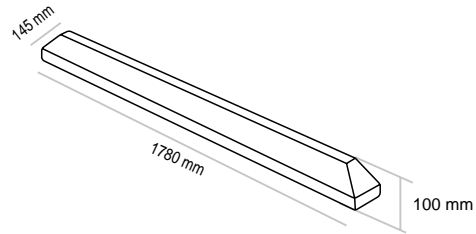

Separator TIR – PARKSTOP

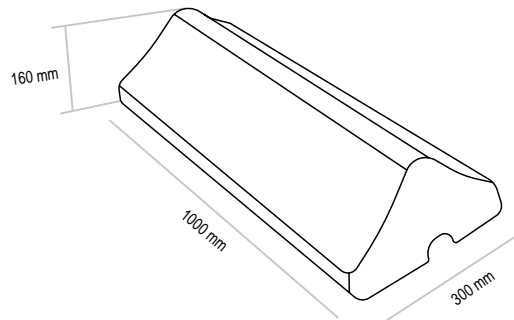

Rubber separator TIR

CODE  
10-1030-02 26 kg 6x



Separator ruchu punktowy parkingowy U-25b, VB PS-c (PVC-modułowy)

PVC parking separator U-25b, VB PS-c

CODE    
10-1060- 01 02 23 kg 3x + 3x

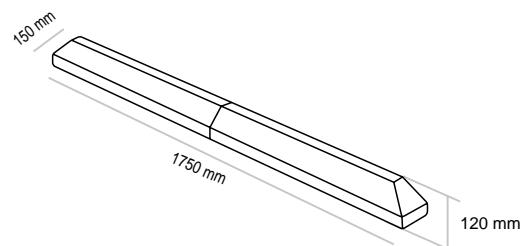



Separator ruchu punktowy parkingowy U-25b, VB PS-s (PVC-krótki)

PVC parking separator U-25b, VB PS-s

CODE 10-1080- 01 02 11 kg 3x

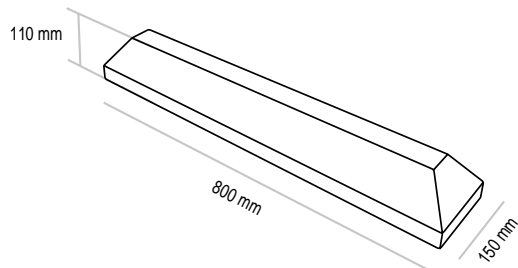

Separator ruchu punktowy rowerowy (bike separator) U-25b, VB BS

Rubber bike separator U-25b, VB BS

CODE 10-1000- 01 02 4 kg 3x

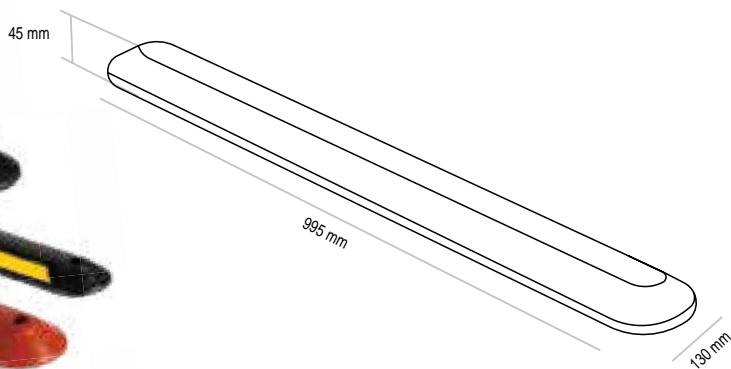

Separator ruchu ciągły U-25a, VB TS U-25a (PVC)

Road separator U-25a, VB TS U-25a (PVC)

CODE 10-6011-02 13,3 kg 2x + 1x

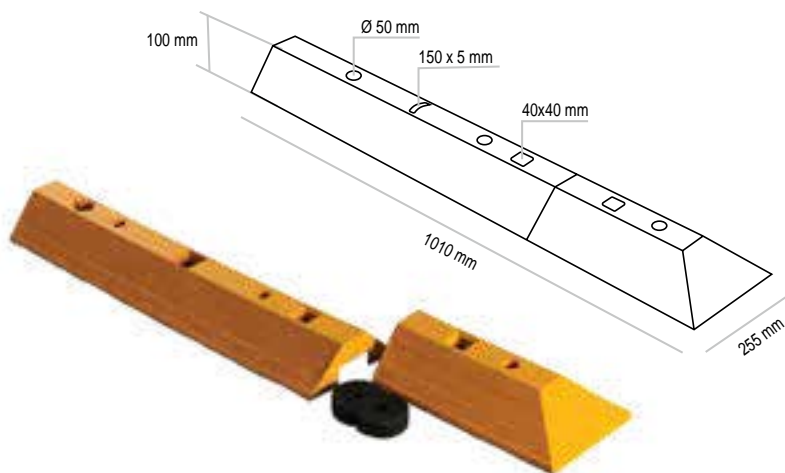

Separator ruchu punktowy U-25b, VB TS U-25b (PVC)

Road separator U-25b, VB TS U-25b (PVC)

CODE

10-1011-02



7,5 kg



2x

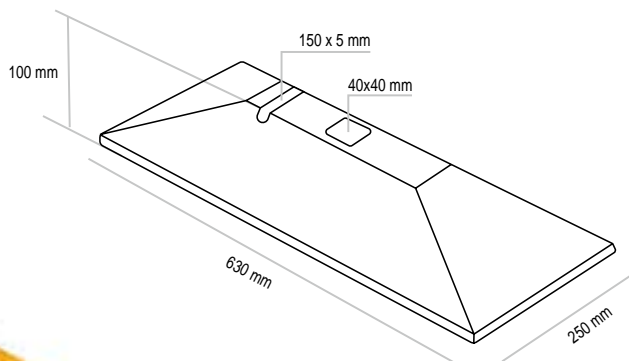

Gumowy krawężnik elastyczny

Rubber elastic kerb

CODE

10-1250- 01



02



11 kg



10-1250- 11

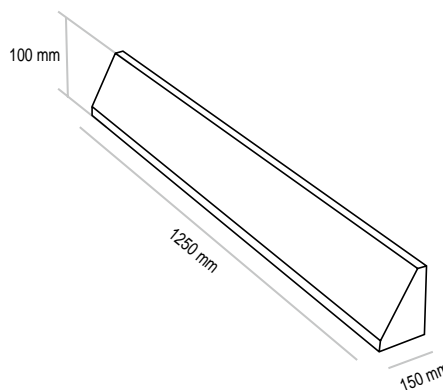

Gumowy krawężnik BRO 1000

Rubber kerb BRO 1000

CODE

10-1000-14



23 kg



3x

10-1000-15

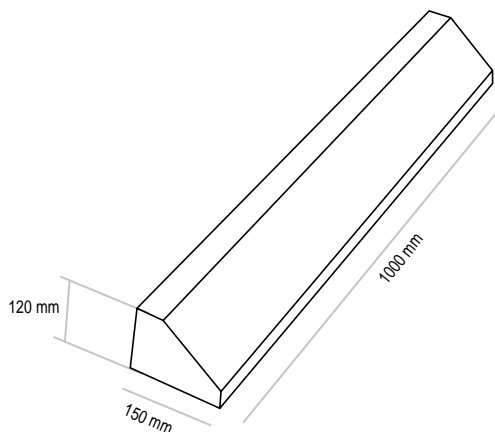



Najazd gumowy 10 cm/15 cm

Rubber kerb ramp 10 cm/15 cm

CODE

CODE	kg	3x
12-0010-01	10 kg	3x
12-0010-02	3,4 kg	3x
12-0015-01	17 kg	3x
12-0015-02	5,8 kg	3x

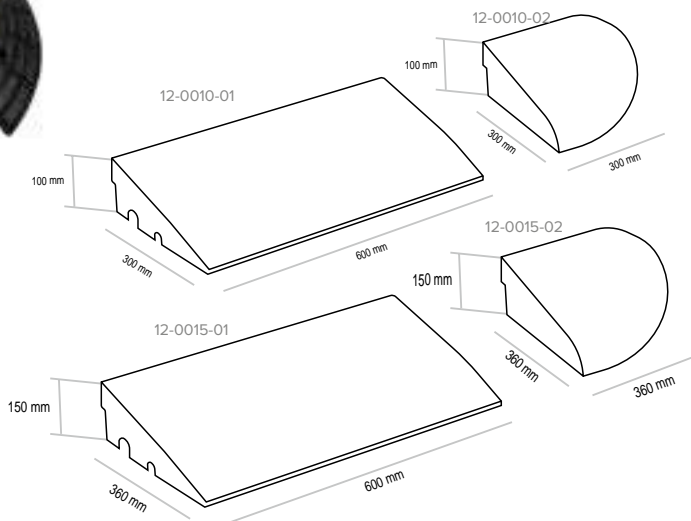

Separator ruchu punktowy parkingowy U-25b, VB PS-s (PVC-krótki)

PVC parking separator U-25b, VB PS-s

CODE

10-1100-02	1,7 kg
------------	--------

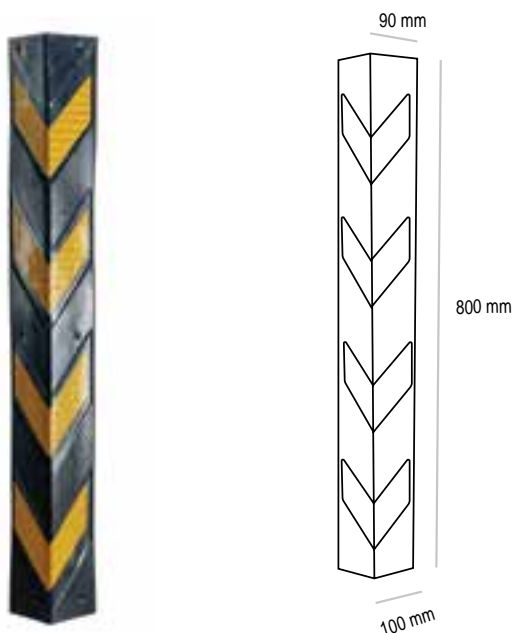

Azyl „Azyl 50” TI-c, TI-e, TI-i

Traffic island „PVC Azyl 50” TI-c, TI-e, TI-i

CODE

CODE	Weight	Screws
05-0500-01	18 kg	4x
05-0500-02	19,5 kg	4x
05-0500-03	20 kg	4x



05-0500-03



05-0500-01

05-0500-02

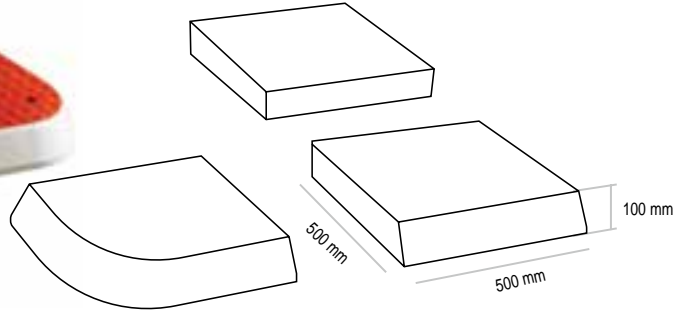

Mini azyl

Traffic island „PVC Mini azyl”

CODE

CODE	Weight	Color	Screws
05-0050-10	10	01	4x
05-0050-20	20	02	4x



05-0050-10



05-0050-20



05-0050-01



05-0050-02

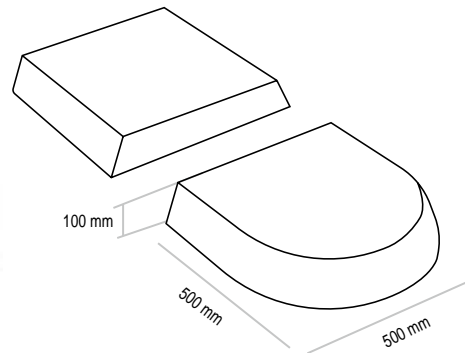



PACHOŁKI DROGOWE I ZNAKI

CONES AND SIGNS

PL Klasykne pachołki drogowe U-23 są w różnych wymiarach, wagach, a także w kilku wariantach oklejania - od zwykłej białej taśmy po odblaskową.

Grupa najlżejszych pachołków wykonanych z elastycznego tworzywa PVC w kolorze pomarańczowym, posiadających białe pasy, idealnie sprawdzi się jako zabezpieczenie doraźne, oznakowanie niebezpiecznego miejsca lub zabezpieczenia świeżo malowanych linii na jezdni. Te pachołki występują w trzech rozmiarach - 30, 50 i 75 cm.

Kolejna grupa trochę cięższych pachołków jest również wykonana z elastycznego PVC, a ich stabilność zapewnia gumowa podstawa. Różnica między tymi, a najlżejszymi pachołkami wynosi około 0,5 kg.

Pachołki w kolorze czerwonym i oklejone fluorescencyjną folią, są dedykowane do wyznaczania torów jazdy dla aut w miejscu prowadzenia krótkotrwałych robót. Te elastyczne pachołki sprawdzą się też na placach manewrowych.

Ostatnia grupa pachołków - najcięższych i najstabilniejszych - obejmuje U-23 o wymiarach 50, 75 lub 100 cm. Te pachołki są wykonane z twardego tworzywa PVC w kolorze czerwonym, a ich podstawa z gumowego recyklatu.

Pachołki, w zależności od zapotrzebowania klienta, mogą być czyste albo oklejone taśmą I lub II generacji odblaskowości.

Grupa znaków obejmuje głównie tablice kierujące i skrajnie umieszczane w pasie drogi w celu zabezpieczania robót drogowych.

Ta szczególna grupa wyrobów wykonanych z wysokogatunkowego polietylenu odpornego na warunki atmosferyczne (U-21, U-6), oraz elastycznego PVC (U-24) obejmuje też znaki U-21 z metalowym wzmocnieniem co gwarantuje ich wytrzymałość przy intensywnej eksploatacji. Te produkty przeznaczone są głównie do oznakowania tymczasowego. Znaki umieszczane są w dedykowanych dla nich podstawach lub przytwierdzone do podłoża za pomocą kołków rozporowych (U-24).

Znaki są oklejane odblaskową folią I lub II generacji zgodnie z zapotrzebowaniem klienta.

ENG The lightest group of cones is made of flexible PVC. Colored in orange and with white stripes, they are perfect for temporary protection by marking a dangerous place or securing freshly painted lines on the road. These bollards come in three sizes - 30, 50 and 75 cm. Another group of slightly heavier cones is also made of flexible PVC, and their stability is ensured by a rubber base. The difference between these and the lightest cones is about 0.5 kg.

Cones in red are covered with fluorescent foil and are dedicated to marking driving paths for cars in places of short-term works. These flexible cones will also prove useful in maneuvering yards.

The last group of cones - the heaviest and most stable - includes U-23s measuring 50, 75 or 100 cm. These cones are made of hard red PVC and their base is made of recycled rubber material.

These cones, depending on the customer's needs, can be clear or taped with the 1st or 2nd generation reflective tape.

The group of signs mainly includes beacons placed at road borders in order to secure road works.

This special group comprises products made of high-quality polyethylene resistant to weather conditions (U-21, U-6) and flexible PVC (U-24). It also includes U-21 signs with metal reinforcement, which guarantees their durability in intensive use. This product group is mainly intended for temporary marking. The signs are placed in dedicated bases or attached to the ground with expansion bolts (U-24).

The signs are covered with a reflective branch of the 1st or 2nd generation according to the customer's needs.



Pachołki drogowe ciężkie U-23, 50/75/100



Heavy duty road cones U-23, 50/75/100



U-23/100
11-1000-02

U-23/75
11-7500-01

U-23/50
11-5000-00

	CODE			
50 cm ▲	11-5000-	01	02	3 kg
▲	11-7500-00			3 kg
75 cm ▲	11-7500-	01	02	5,7 kg
▲	11-7500-00			5,7 kg
100cm ▲	11-1000-		02	9 kg

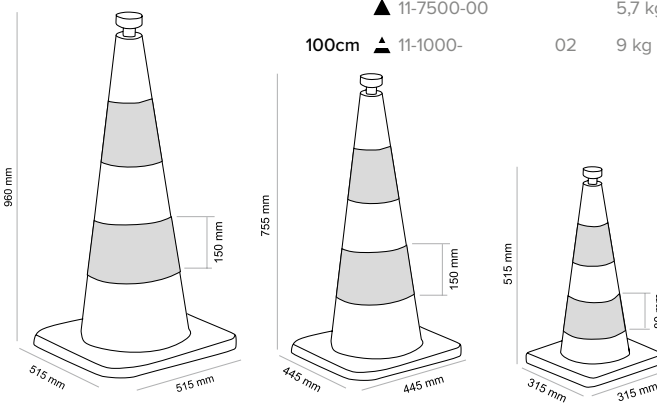

NEW Zwijana taśma na pachołek

Retractable belt barrier

CODE
9 m 11-0900-10





Pachołki drogowe U-23, 50/75

Road cones U-23, 50/75

CODE 

- 50 cm ▲ 11-0050-02 1,5 kg
- 75 cm ▲ 11-0075-02 4 kg

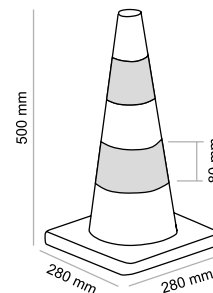
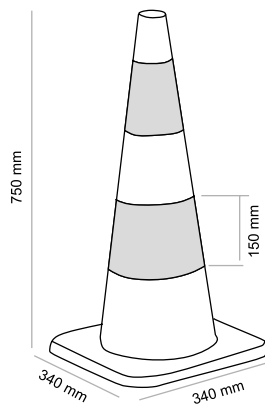

Pachołki drogowe lekkie U-23, 30/50/75

Light road cones U-23, 30/50/75

CODE 

- 30 cm ▲ 11-0030-02 0,4 kg
- 50 cm ▲ 11-0050-00 1,5 kg
- 75 cm ▲ 11-0075-00 4 kg

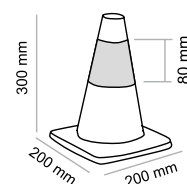
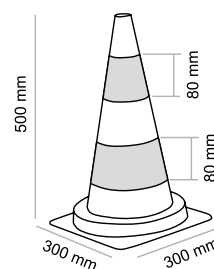
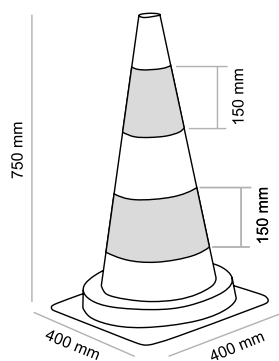



WIVA®

Tablica kierująca U-21 WIVA

Flexible beacon U-21 WIVA

CODE

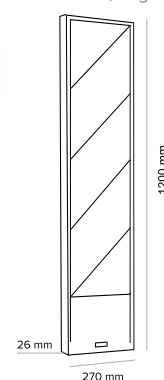
 I folia 11-5005-01
 II folia 11-5005-02

 1,8 kg
 1,8 kg

Tablica kierująca, skandynawska

Flexible skandinavian beacon

CODE

11-5003-02



1,2 kg

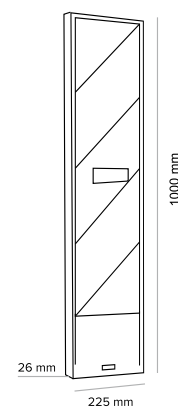

Tablica kierująca U-21

Beacon U-21

CODE

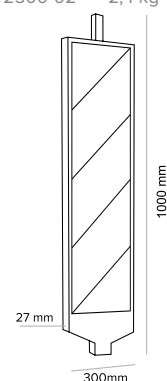
 I folia 11-2500-10 2,4 kg
 II folia 11-2500-20 2,4 kg
 ECO 11-2500-02 2,4 kg



Tablica kierująca U-6

Beacon U-6



U-25b
10-1011-02

CODE

11-6000-03

11-6000-04



0,8 kg

0,8 kg

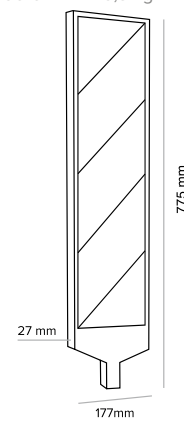

Tablica kierująca, elastyczna U-6

Flexible beacon U-6



U-25b
10-1011-02

CODE

11-6000-01

11-6000-02



0,35 kg

0,35 kg

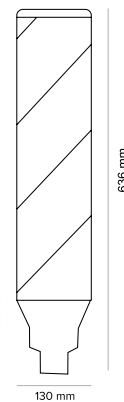

vb traffic Tablica uchylna U-24

Flexible delineator U-24

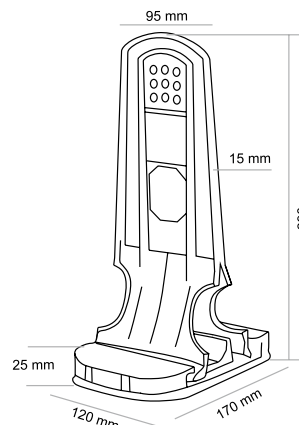

CODE

11-6000-01

11-6000-02



0,8 kg

0,35 kg



SŁUPKI

POSTS





U-1a

U-1a



U-1b

Słupek prowadzący U-1a i U-1b

Delineator post U-1a and U-1b

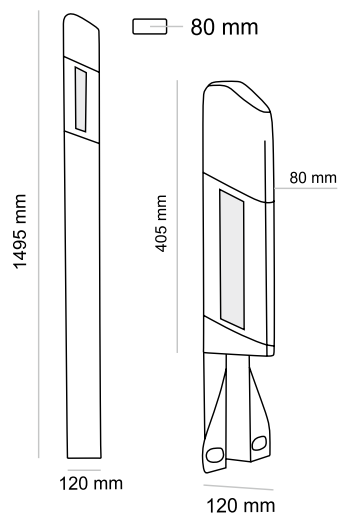

	CODE	
U-1a	11-7001-02	1,1 kg
U-1b	11-7001-03	0,95 kg



nakładka antyporostowa
11-7003-01

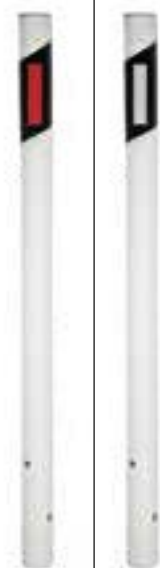

U-1a LT

U-1a LT



U-1b LT

Słupek prowadzący U-1a LT i U-1b LT

Delineator post U-1a LT and U-1b LT

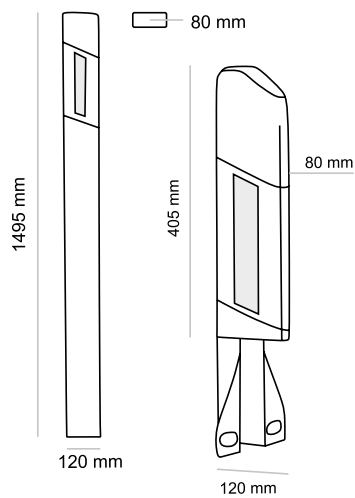

	CODE	
U-1a LT	11-7011-02	1,2 kg
U-1b LT	11-7011-03	0,95 kg



U-1a EE

U-1a EE

Słupek prowadzący U-1a EE

Delineator post U-1a EE

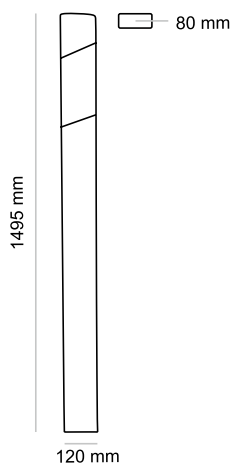

	CODE	
U-1a EE	11-7021-02	1,1 kg



Słupek prowadzący U-1a LV, elastyczny

Delineator post U-1a LV, flexi

CODE



LV	11-7031-02	1 kg
FLEX	11-7001-04	1 kg

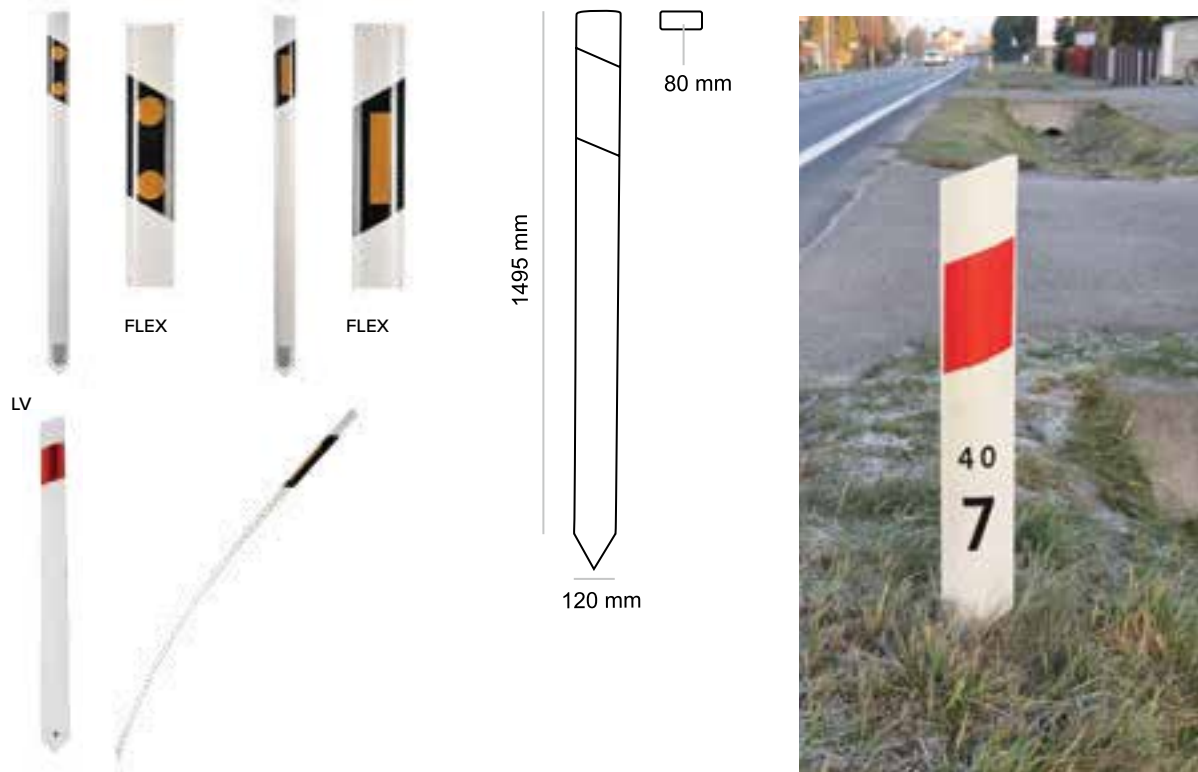

Nakładka antyporostowa do słupka U-1a

Anti-grass plate for U-1a post

CODE



11-7003-01	1,1 kg
------------	--------



Element odblaskowy na U-1a „wilcze oczy”

Wildlife warning reflector for U-1a post



CODE



<input type="checkbox"/> <input type="checkbox"/> <input type="checkbox"/>	11-7172-01	0,25 kg
--	------------	---------

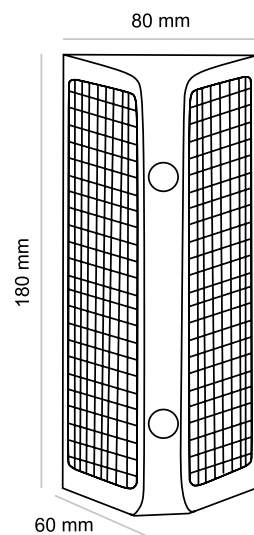



Słupek do podstaw P003, P009

Cylinder tube for base P003, P009

CODE 
11-8001-01 1,1 kg





 $\varnothing 100$ mm

Metalowy słupek U-12b

Metal post U-12b

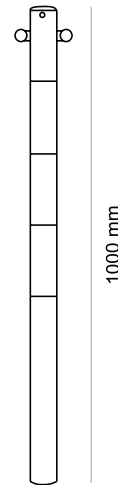
CODE 
11-1000-01 2,3 kg
11-1000-02 2,3 kg



 $\varnothing 60$ mm



P015
09-0015-02

Słupek przeszkodowy U-5a i U-5b

Warning bollard U-5a and U-5b

CODE 

U-5a 11-6001-02 2,5 kg
U-5b 400 11-6002-02 5,3 kg
U-5b 400 11-6004-02 4,7 kg
U-5b 600 11-6003-02 8 kg

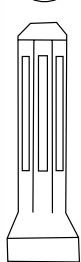
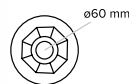

300mm

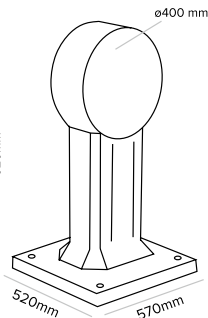

570mm

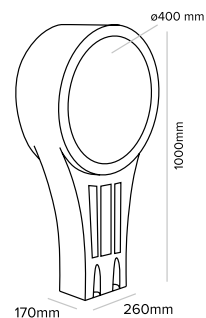

260mm

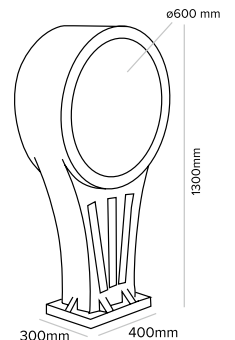

400mm



T-flex

FLEXPIN

Słupek elastyczny T-flex

Elastic post T-flex

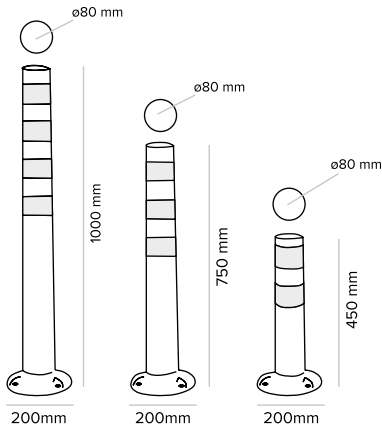

CODE



45	11-0045-11	0,85 kg	3x
75	11-0075-11	1,32 kg	3x
100	11-0100-11	1,5 kg	3x



Słupek uchylny FLEXPIN

FLEXPIN post

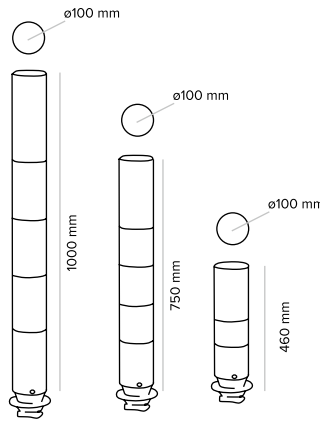

CODE



46	11-2046-02	2,2 kg	4x
75	11-2075-02	2,5 kg	4x
100	11-2100-02	2,6 kg	4x



Słupek U-2

U-2 post

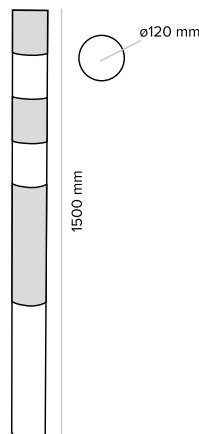

CODE



11-1500-02	1,8 kg
------------	--------



Słupek z podstawą MAG-1



MAG-1 post with base

CODE 
11-0860-01 3,3 kg



Słupek z podstawą MAG-2



MAG-2 post with base

CODE 
 11-0900-01 0,5/3,35 kg
 11-0900-02 0,5/3,35 kg



Łańcuch plastikowy

Plastic chain

CODE 
 16-0025-01 1,54 kg
 16-0025-02 1,54 kg

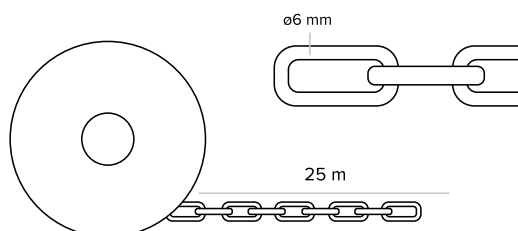



Słupek U-12c
U-12c post

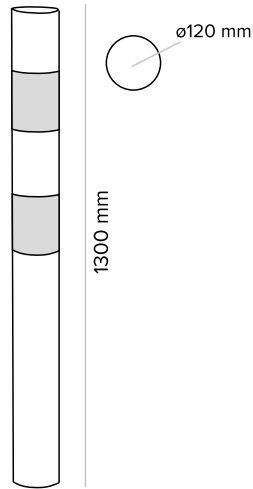

CODE 
11-1300-13 7 kg



Słupek U-12c FLEX
U-12c post FLEX

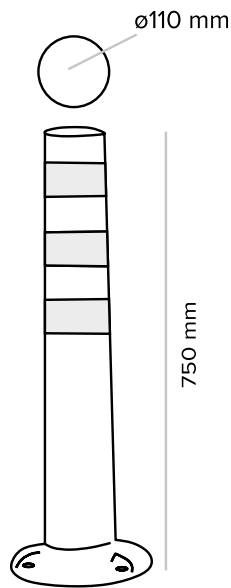

CODE 
11-1100-12 7 kg



BARIERY DROGOWE

ROAD BARRIERS



vb traffic
Zapora drogowa U-20
 Road barrier U-20 VB Traffic

CODE 
 07-2000-03 10,5 kg

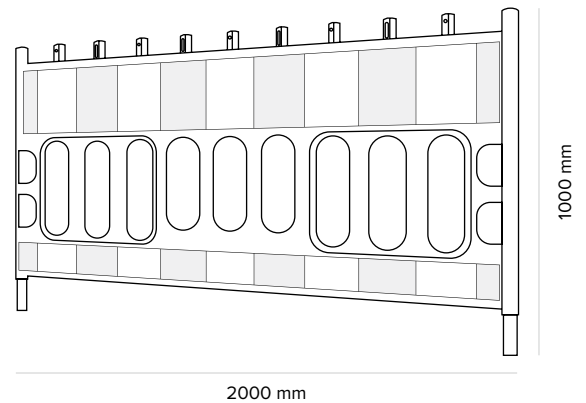
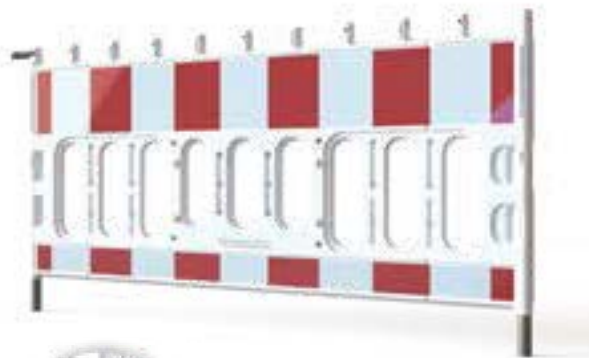

Podstawa
 P010 lub P014

Zapora drogowa Gate
 Road barrier Gate

CODE 
 07-2000-01 10,5 kg

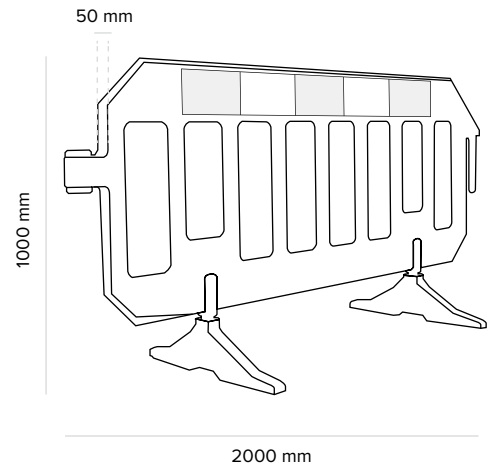



Zapora drogowa EuroVision

Road barrier EuroVision

CODE



07-2000-02 10,5 kg

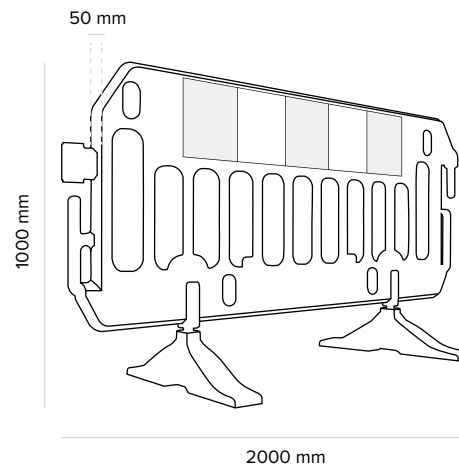

Bariera X1 / X2

Road barrier X1 / X2

CODE



X1 07-1000-10 7/10 kg
X2 07-2000-10 11/14 kg

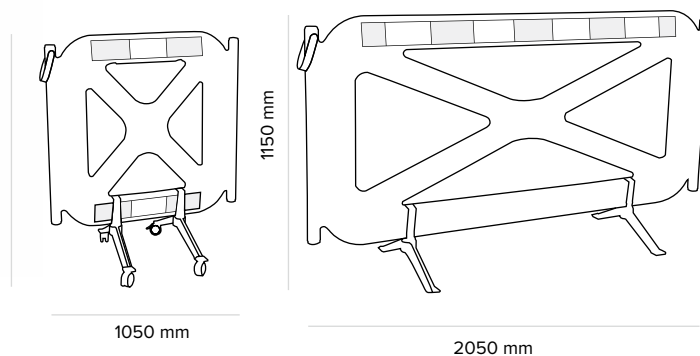



Bariera U-14e
Barrier U-14e

CODE 

U-14e 500 11-0500-14 7 kg
U-14e 800 11-0800-14 9 kg

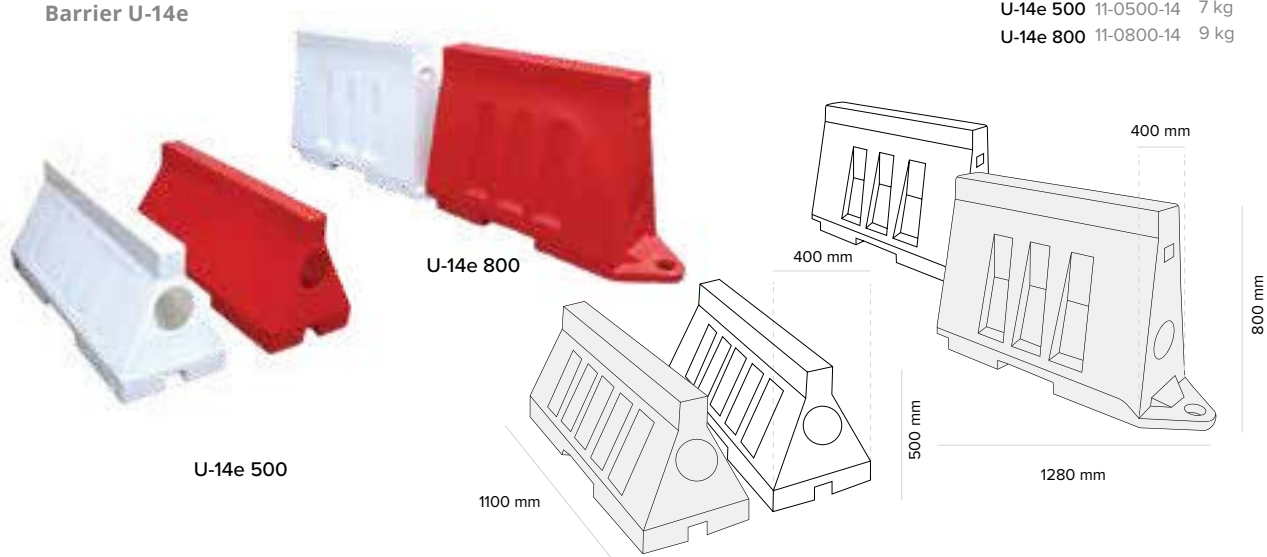

Bariera harmonijkowa
Red Expandable Barrier

CODE 
07-2000-04 9 kg

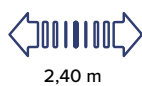



Osłona zabezpieczająca U-15b

Traffic dividing marker U-15b

	↑	CODE	
U-15b r:500	980 mm	11-0500-15	6 kg
U-15b r:750	1300 mm	11-0750-15	36 kg
U-15b r:1000	1600 mm	11-1000-15	60 kg

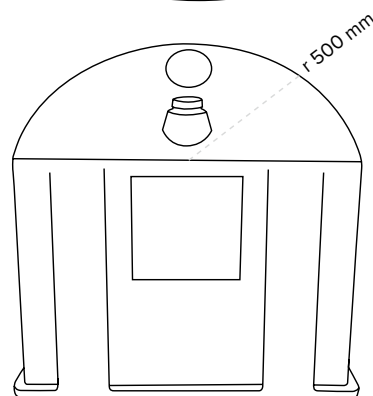
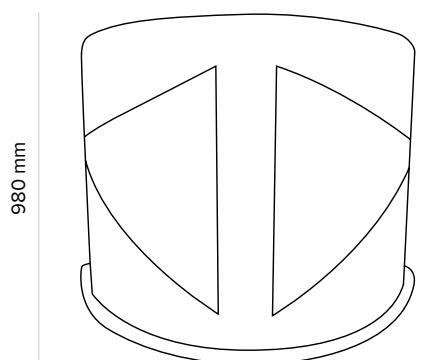

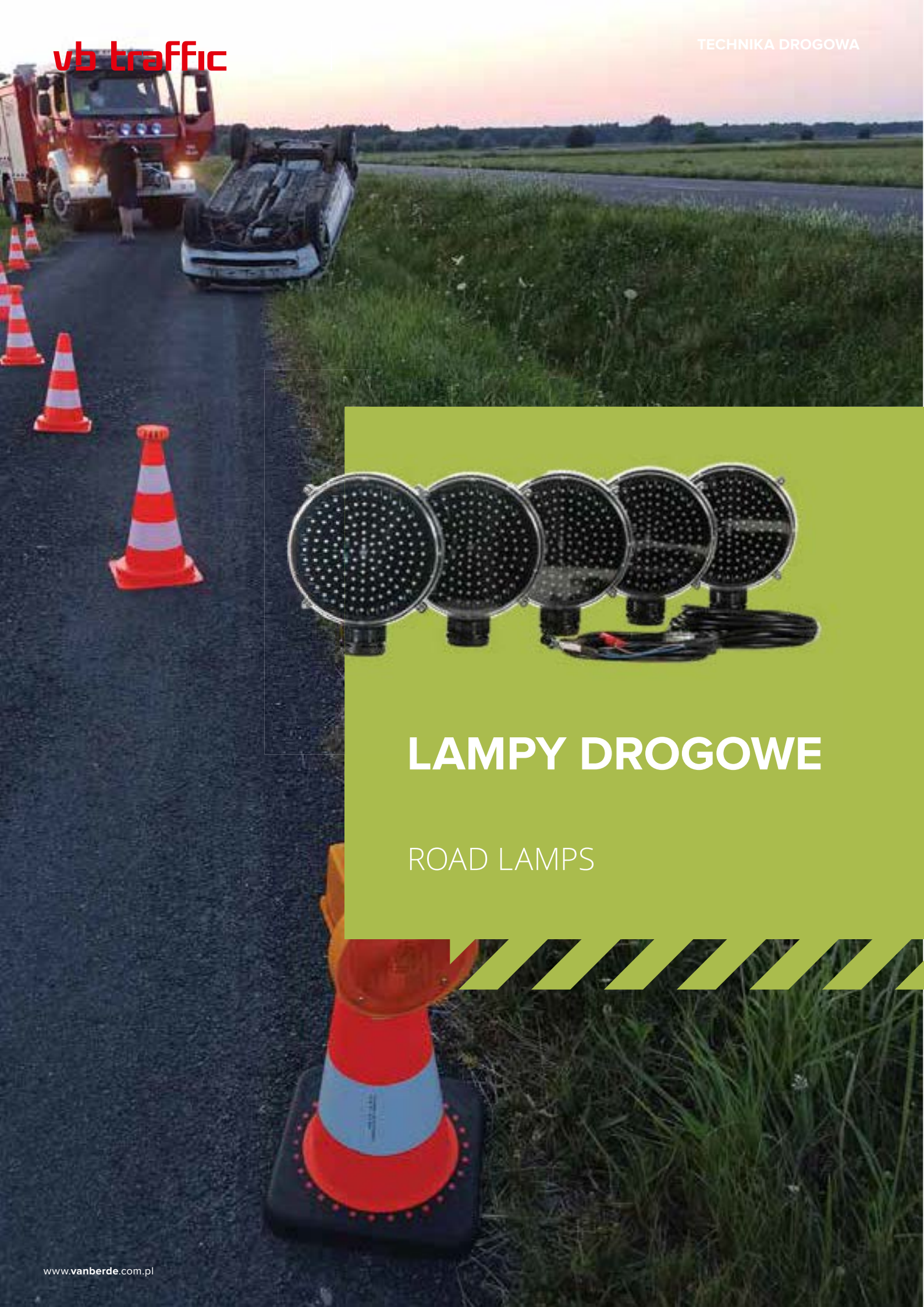

LAMPY DROGOWE

ROAD LAMPS





MiniStar 1000

MiniStar 1000

CODE



08-1000- 01 02 0,5 kg 20 szt./pcs - 11 kg 358/2800 h



01-0000-20

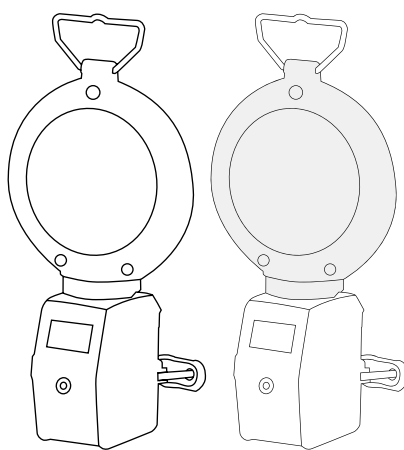

340 mm

110 mm



Star 2000

Star 2000

CODE



08-2000- 01 02 0,7 kg 12 szt./pcs - 8,5 kg 713/4500 h



01-0000-20

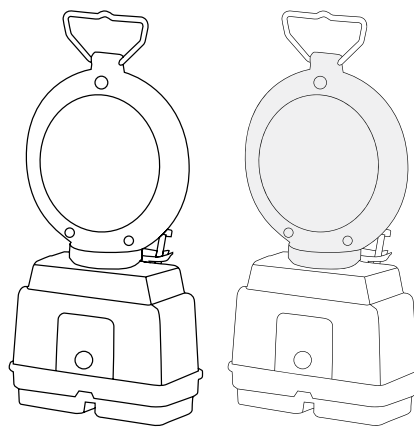

360 mm

190 mm





StarFlash 2000
StarFlash 2000

CODE
 ■ 08-2000-07 1 kg 12 szt./pcs - 12 kg 140/910 h



01-0000-20

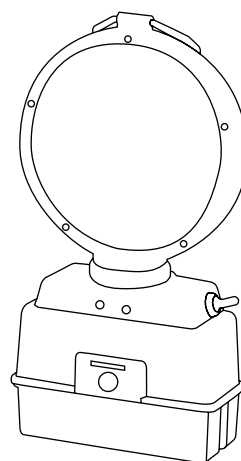

380 mm

150 mm



Solstar
Solstar

CODE
 ■ 08-8000-11 0,5 kg 20 szt./pcs - 11 kg

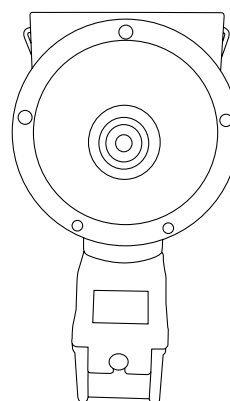

330 mm

100 mm





CONESTAR 1000

CONESTAR 1000

CODE



08-1000-11 0,55 kg 10 szt./pcs - 5,5 kg

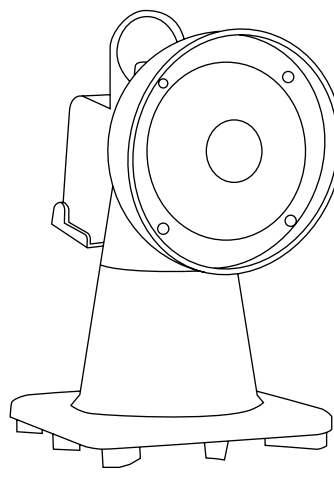

185 mm



Bateria Star 6V/7Ah/50Ah

Battery Star 6V/7Ah/50Ah

CODE



7Ah	01-0000-01	0,5 kg	24 szt./pcs - 12 kg	35 dni/days*
28Ah	01-0000-03	0,92 kg	12 szt./pcs - 11,5 kg	140 dni/days*
50Ah	01-0000-02	0,7 kg	12 szt./pcs - 8,4 kg	225 dni/days*

* Dotyczy zasilania lampy MiniStar/ Refers to powering the MiniStar lamp.

Minimalna utrata pojemności w magazynie:
Minimum loss of capacity in stock:

1 rok/year - 5%
2 lata/years - 8%



-20C do 50C

Sprawność baterii:
Humidity range:
25% do 85C Rh

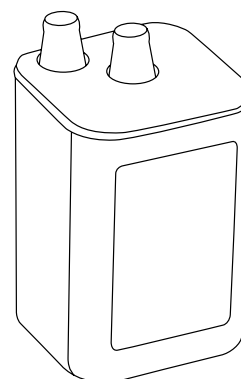

100 mm



Pałka LED do kierowania ruchem

LED warning baton

CODE

8-3001-01
8-3001-03



0,4 kg
2,46 kg



1 szt./pcs - 0,4 kg
3 szt./pcs - 2,46 kg

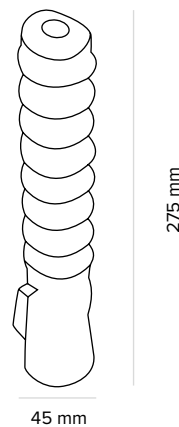

45 mm

275 mm

Światło ostrzegawcze MINIBŁYSK LED

MINIFLASH LED light

CODE

08-0001- 01 02
08-0001- 01 02



0,35 kg
3,08 kg



1 szt./pcs - 0,35 kg
6 szt./pcs - 3,08 kg

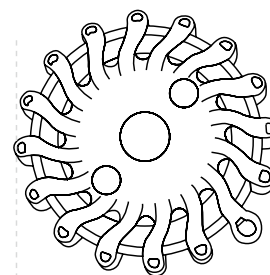

105 mm

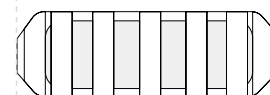

35 mm



Pałka do kierowania ruchem

Warning baton

CODE



08-3000-00 0,5 kg



Lizak do kierowania ruchem

Warning baton

CODE



08-0000-00 0,4 kg 24 szt./pcs - 12 kg

LED 08-0000-01 0,7 kg 12 szt./pcs - 8,4 kg



Fala przewodowa

Barricade light

CODE



02-3000-01 1,9 kg 650/1100 h



Fala bezprzewodowa

Wireless barricade light

CODE



20-2000-74 0,7 kg 290/2000 h

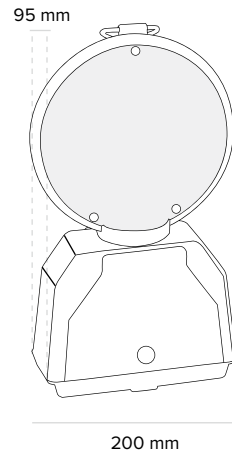

365 mm



Fala przewodowa Economic

Barricade light Economic

CODE



20-1900-01 1 kg 290/2000 h

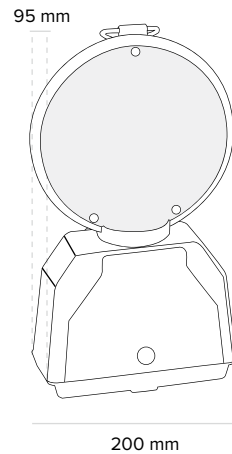

365 mm



Fala na belce

Barrier with 5 LED optics

CODE



20-1900-02 9,5 kg 290/2000 h



170 mm

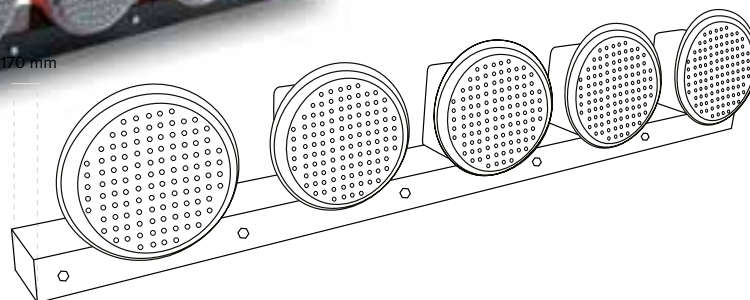

280 mm



1400 mm



PANELE LED I LAMPY OSTRZEGAWCZE

LED OPTICS
AND WARNING LIGHTS



PL **Tę kategorię otwiera wysoce wydajna 200 mm lampa LED, spełniająca wymagania normy UNI EN12352. Ma zastosowanie na placach budów, na autostradach i w kolejnictwie.**

Materiał PMMA (szkło akrylowe), z którego są wykonane innowacyjne elementy optyczne - przezroczyste szkła FRESNEL - cechują się wysokim stopniem odbicia i rozprzestrzeniania światła, co skutkuje wysoką wydajnością przy mniejszej liczbie LED.

19 sztuk LED użytych w tej lampie pozwala osiągnąć stopień jasności świecenia L8H, bez konieczności wspomagania tradycyjnym oświetleniem. To rozwiązanie pozwala zredukować zużycie energii i wydłużyć czas działania lampy. Oprawa lampy (5,8 cm) wykonana jest z materiału odpornego na działanie promieni UV, jest odporna na uszkodzenia i zmienne warunki atmosferyczne.

Kompaktowe wymiary lampy pozwalają montować ją na różnego rodzaju konstrukcjach budowlanych, panelach, znakach drogowych, a przy użyciu specjalnego uchwytu także na słupkach, pachołkach drogowych i innych urządzeniach do tymczasowego zarządzania ruchem drogowym.

Kolejne produkty z tej gamy to cały szereg lamp i paneli, które różnią się średnicą i ilością diod LED w poszczególnych panelach. Wszystkie świecą żółtym światłem LED.

Panele są pojedyncze lub podwójne, mogą być montowane zarówno na tablicach tymczasowych jak i stałych. Ich szybki i łatwy montaż jest możliwy za pomocą 3 otworów montażowych. Panel LED ma niski opór mocy, więc może współpracować z zasilającym panelem fotowoltaicznym. Lampy LED można przymocować do rur ocynkowanych o średnicy 42 mm (ø230) oraz 60 mm (ø340) za pomocą łącznika.

ENG **This category opens a highly efficient 200mm LED lamp that meets the requirements of the UNI EN12352 standard. It is used on construction sites, highways and railways.**

The PMMA material (acrylic glass), from which the innovative optical elements are made - transparent FRESNEL glasses - are characterized by a high degree of reflection and light spreading, which results in high efficiency with fewer LEDs.

The 19 LEDs used in this lamp allow for achieving the L8H brightness level without the need to support it with traditional lighting. This solution allows reducing energy consumption and extending the life of the lamp. The lamp holder (5.8 cm) is made of a material resistant to UV rays, and it is resistant to damage and changing weather conditions.

The compact dimensions of the lamp allow it to be mounted on various types of building structures, panels, road signs, and, by use of a special holder, also on posts, road cones and other devices for temporary traffic management.

The following products in this range are many types of lamps and panels, which differ in the size of the diameter and the number of LEDs in individual panels. They all shine with yellow LED light.

The panels are single or double and can be mounted on both temporary and permanent boards. Their quick and easy assembly is possible by use of 3 mounting holes. The LED panel has low power resistance, so it can work with a photovoltaic panel for power. LED lamps can be attached to galvanized pipes with a diameter of 42 mm (ø230) and 60 mm (ø340) with a connector.



Panel LED ø100

LED optic ø100

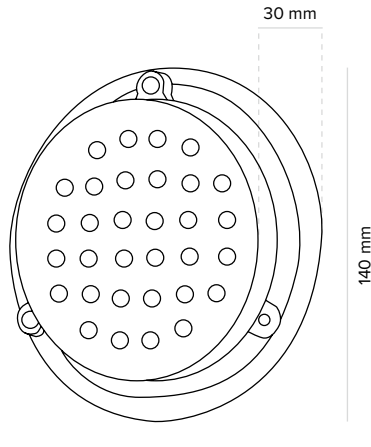

140 mm

CODE

20-0100-01



0,18 kg



LED 32



-15°C – +85°C



na zamówienie
on request



18Ah/40Ah/
100Ah/180Ah



UNI EN 12352
klasa L8H



tak/yes



20/50 W



- standardowy błysk/ standard flash mode/
55h/120h/310h/570h
- potrójny i krótki błysk/ tri-flash and short mode/
110h/250h/630h/1100h



12/24 V

Panel LED ø200

LED optic ø200

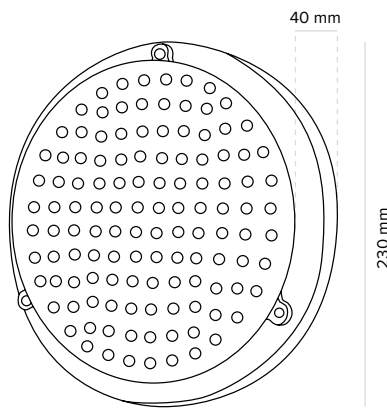

230 mm

CODE

20-0200-01



0,48 kg



LED 120



-15°C – +85°C



na zamówienie
on request



18Ah/40Ah/
100Ah/180Ah



UNI EN 12352
klasa L8H



tak/yes



20/50 W



- standardowy błysk/ standard flash mode/
55h/120h/310h/570h
- potrójny i krótki błysk/ tri-flash and short mode/
110h/250h/630h/1100h



12/24 V

Panel LED ø230

LED optic ø230

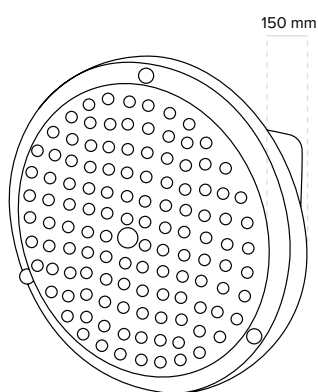

230 mm

CODE

20-0230-01



1 kg



LED 120



-15°C – +85°C



na zamówienie
on request



18Ah/40Ah/
100Ah/180Ah



UNI EN 12352
klasa L8H



tak/yes



20/50 W



- standardowy błysk/ standard flash mode/
55h/120h/310h/570h
- potrójny i krótki błysk/ tri-flash and short mode/
110h/250h/630h/1100h



12/24 V

Panel LED ø300

LED optic ø300

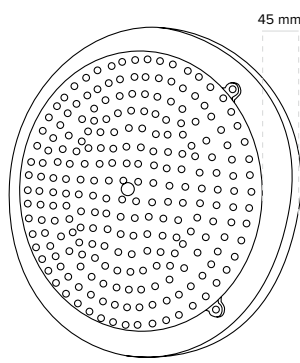

340 mm

CODE

20-0300-01



1,44 kg



LED 232



-15°C – +85°C



na zamówienie
on request



18Ah/40Ah/
100Ah/180Ah



UNI EN 12352
klasa L9M



tak/yes



50 W



- standardowy błysk/ standard flash mode/
55h/120h/310h/570h
- potrójny i krótki błysk/ tri-flash and short mode/
110h/250h/630h/1100h



12/24 V

Panel LED ø340

LED optic ø340

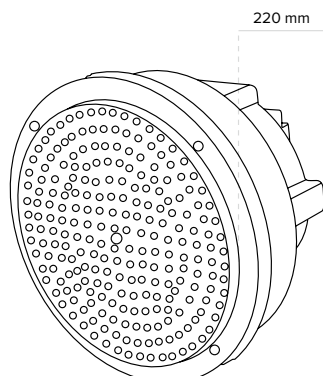

340 mm

CODE

20-0340-01



2,52 kg



LED 232



-15°C – +85°C

na zamówienie
on request18Ah/40Ah/
100Ah/180AhUNI EN 12352
klasa L9M

tak/yes



50 W



- standardowy błysk/ standard flash mode/
55h/120h/310h/570h
- potrójny i krótki błysk/ tri-flash and short mode/
110h/250h/630h/1100h



12/24 V

Panel LED 2x ø100

LED optic 2x ø100

**CODE**

20-0100-02



0,64 kg



LED 2x32



-15°C – +85°C

na zamówienie
on request18Ah/40Ah/
100Ah/180AhUNI EN 12352
klasa L8H

tak/yes



20/50 W



- standardowy błysk/ standard flash mode
120h/270h/680h/1200h
- potrójny i krótki błysk/ tri-flash and short mode
250h/550h/1300h/2450h



12/24 V



140x140x30 mm

Panel LED 2x ø200

LED optic 2x ø200

**CODE**

20-0200-02



1,28 kg



LED 2x120



-15°C – +85°C

na zamówienie
on request18Ah/40Ah/
100Ah/180AhUNI EN 12352
klasa L8H

tak/yes

standard 110 W
tri-flash 50 W

- standardowy błysk/ standard mode
19h/40h/100h/190h
- potrójny i krótki błysk/ tri-flash and short mode
55h/120h/310h/570h
- alternatywny standardowy błysk/ alternate standard
mode 15h/35h/95h/165h
- alternatywny potrójny i krótki błysk/ alternate tri-fla-
sh and short mode 50h/120h/310h/565h



12/24 V



230x230x40 mm

Lampa LED 2x o230

Lampa LED 2x o230



CODE	1,94 kg	LED 2x120
20-0230-02		
-15°C – +85°C	na zamówienie on request	18Ah/40Ah/100Ah/180Ah
UNI EN 12352 klasa L8H	tak/yes	standard 110 W tri-flash 50 W
- standardowy błysk/ standard mode 19h/40h/100h/190h		
- potrójny i krótki błysk/ tri-flash and short mode 55h/120h/310h/570h		
- alternatywny standardowy błysk/ alternate standard mode 15h/35h/95h/165h		
- alternatywny potrójny i krótki błysk/ alternate tri-flash and short mode 50h/120h/310h/565h		
12/24 V	230x230x150 mm	

Panel LED 2x o300

LED optic 2x ø300



CODE	2,68 kg	LED 2x232
20-0300-02		
-15°C – +85°C	na zamówienie on request	18Ah/40Ah/100Ah/180Ah
UNI EN 12352 klasa L9M	tak/yes	standard 110 W tri-flash 50 W
- standardowy błysk/ standard mode 15h/40h/100h/190h		
- potrójny i krótki błysk/ tri-flash and short mode 35h/85h/210h/380h		
- alternatywny standardowy błysk/ alternate standard mode 10h/22h/60h/110h		
- alternatywny potrójny i krótki błysk/ alternate tri-flash and short mode 35h/85h/210h/380h		
12/24 V	340x340x45 mm	

Lampa LED 2x o340

LED lamp 2x ø340mm



CODE	2,52 kg	LED 2x232
20-0340-02		
-15°C – +85°C	na zamówienie on request	18Ah/40Ah/100Ah/180Ah
UNI EN 12352 klasa L9M	tak/yes	standard 110 W tri-flash 50 W
- standardowy błysk/ standard mode 15h/40h/100h/190h		
- potrójny i krótki błysk/ tri-flash and short mode 35h/85h/210h/380h		
- alternatywny standardowy błysk/ alternate standard mode 10h/22h/60h/110h		
- alternatywny potrójny i krótki błysk/ alternate tri-flash and short mode 35h/85h/210h/380h		
12/24 V		



SYGNALIZACJA TYMCZASOWA I ZNAKI AKTYWNE

TEMPORARY SIGNALIZATION
AND ACTIVE SIGNS



PL Sygnalizacja tymczasowa obejmuje cały szereg urządzeń elektrycznych, także z zasilaniem solarnym. Sprawdzają się one jako stałe zabezpieczenie przy drogach, jak też przy przejściach dla pieszych i w trakcie robót drogowych.

Rewolucyjną propozycją jest zestaw StarWalker. To innowacyjne rozwiązanie na pewno sprawdzi się zarówno w aglomeracjach jak i w małych miejscowościach. Zestaw znaków D-6 z oświetleniem i czujnikami ruchu, wzbogacony o całą gamę produktów dodatkowych, wymusza na kierowcach zmniejszenie prędkości i zatrzymanie pojazdu przed przejściem. Kompletny zestaw StarWalker, w całości dostępny u jednego dostawcy, gwarantuje stu procentowe bezpieczeństwo pieszych. Różnego rodzaju radary prędkości, występujące w różnych wariantach, zasilane z sieci lub poprzez energię słoneczną - to nasze propozycje do wykorzystania w niewralgicznych miejscach na drodze. Urządzenia te mają zaawansowany system przechowywania energii, który zapewnia ich sprawne działanie w dzień i w nocy. Wyrobem dedykowanym do zabezpieczania robót drogowych jest bezprzewodowa sygnalizacja tymczasowa. To urządzenie zasilane jest akumulatorem 12 V. Akumulator jest zabezpieczony w wózku, z którym jest połączony wysięgnik panelowy z trzema światłami LED o średnicy 200 lub 300 mm.

Zestaw mikroprocesorów pozwala automatycznie ustawić czas świecenia czerwonych i zielonych lamp.

W przypadku awarii jednej z lamp pojawia się ostrzeżenie na wyświetlaczu. Awaria czerwonej lampy uruchamia synchroniczne świecenie wszystkich lamp na żółto. Błyszczące światło czerwone jest ostrzeżeniem, że nastąpiło zwarcie instalacji elektrycznej. Skrót „Lb” na wyświetlaczu informuje o zużyciu akumulatora. W wózku/pojemniku z akumulatorem znajduje się wewnętrzna bateria podtrzymująca ustawienia systemu, także w czasie wymiany akumulatorów. Istnieje też wersja sygnalizacji tymczasowej z minutnikiem, który zastępuje żółte światło i odlicza czas do zmiany z czerwonego na zielone światło i odwrotnie. Kolejnym rozwiązaniem jest bezprzewodowa fala świetlna, którą montuje się na skrajniach U-21, słupkach lub specjalnie przygotowanej belce. Lampy mają łączność drogą radiową, a ich synchronizacja następuje automatycznie po włączeniu pierwszej. Z lamp można ustawić maksymalnie 8 metrowy panel. Alternatywą jest też fala przewodowa zasilana akumulatorem lub bateriami.

Proponujemy Państwu również komplet lamp na przyczepę U-26a i fale na belce oraz tablice kierunkowe. Wszystkie te elementy stanowią komplet wyposażenia dla przyczepy wykorzystywanej podczas robót drogowych.

ENG Temporary signalization covers a whole range of electrical devices, including those that are solar-powered. They are used as permanent protection by roads, as well as at pedestrian crossings and during road works.

The StarWalker set is a revolutionary product. This innovative solution works both in agglomerations and in small towns. The D-6 character set with lighting and motion sensors, enriched with a range of additional products, forces drivers to reduce speed and stop their vehicles before crossings. The complete StarWalker kit, fully available from one supplier, guarantees 100% pedestrian safety. Various types of speed radars in many variants, powered from the grid or by solar energy - these are our proposals for use in integral places on the road. These devices have an advanced energy storage system that ensures their efficient operation day and night. A product dedicated to securing road works is wireless temporary signaling. This device is powered by a 12V battery. The battery is secured in a cart to which a panel boom with three LED lights and diameter of 200 or 300 mm is connected.

A set of microprocessors allows you to automatically set the duration of red and green lamps.

In the event of failure of one of the lamps, a warning appears on the display. Failure of the red lamp starts synchronous lighting of all lamps in yellow. Flashing red light is a warning that there has been a short circuit in the electrical system. The abbreviation „Lb” on the display shows the consumption of the battery. The cart / battery box has an internal battery that maintains the system settings, including during battery replacement. There is also a version of the temporary signalization with a timer that replaces the yellow light and counts down the time to change from red to green light and vice versa. Another solution is a wireless light wave, which is mounted on the U-21 extensions, posts or a specially prepared beam. The lamps have radio communication and their synchronization takes place automatically after switching on the first one. The lamps can be set up to a panel of up to 8 meters. An alternative is also a wire wave powered by a rechargeable battery or batteries.

We also offer a set of lamps for the U-26a trailer and waves on the beam as well as direction boards. All these elements constitute a complete set of equipment for a trailer used during road works.

Zestaw aktywny ze znakiem D-6, solar, z podświetleniem przejścia dla pieszych

ACTIVE & SAFE pedestrian crossing with D-6 sign and backlight

USTAWIANIE System został zaprojektowany dla dróg o szerokości od 5 do 15 metrów. Większe szerokości są możliwe, ale stopień oświetlenia na środku ulicy będzie niższy.

Znak musi być zainstalowany przed przejściem dla pieszych, możliwie równoległe. Odległość od centrum osi słupka sygnalizacyjnego i krawędzi podłogi musi wynosić 0,5 metra (tak, aby front sygnału nie dotykał drogi).

SETUP The system is designed for roads with a width of 5 to 15 meters. Larger widths are possible, but the degree of illumination in the middle of the street will be lower.

The sign must be installed in front of a pedestrian crossing, parallel if possible. The distance from the center of the signal pole axis and the edge of the floor must be 0.5 meters (so that the signal front does not touch the road).

CODE

20-0000-19



120 kg



640x200x820 mm

DOWN ↕

9 LED Osram serii Golden Dragon, soczewki eliptyczne 11° x 40°

UP ↕

LED: 12 LED

FRONT ↕

28 LED THT/5 mm / 30° / PWM



100 mm



20-0000-19



11-6003-02



12-2000-01



05-0500-01



15-0020-01





LED md IP68: podświetlenie tablicy znaku/ sign board illumination
 4 x 100 mm: błysk synchroniczny, żółte/ synchro-flash, yellow
 1 x 12 LED: góra, biała/ up, white
 1 x 9 LED: dół, biała/ down, white



12 V, 2x 20 Ah + 50 W



12 V, 100 W, 230 V



12 V, 100 W, 230 V



5°



10 m



25% - 100%
4°



tak/yes

Zestaw aktywny do znaku D-6

Pedestrian detection system for sign D-6

CODE



20-0030-16
20-0050-16
20-0230-16

30 W
50 W
230 V

33 kg
33 kg
17 kg



potrójny błysk/ tri-flash
2x ø100 mm, 2x ø200 mm



33% w ciągu nocy/ by night
100% w ciągu dnia/ by daytime



Doppler radar K-Band
80° poziomy/ horizontal
32° pionowy/ vertical
13 dBm



12 V



tak/yes





Radar Prędkości SPEED LUX

System SPEED LUX



CODE

20-0230-20
20-0000-20



100 W



80-100 m
(150-170 m)



100 mm



230V
SOLAR



19 kg
28 kg



640x750x100 mm
640x750x100 mm



240 V AC, 12 V DC



● ●



LED 4500-8500 mcd
(żywność do 100 000 h)



Radar Prędkości ECO LUX

System ECO LUX



CODE

20-0230-22
20-0000-22



40 W



50-80 m



60 mm



230V
SOLAR



10 kg
13 kg



370x420x90 mm
370x420x90 mm



240 V AC, 12 V DC



● ●



LED 8000 mcd
(żywność do 100 000 h)

Radar Prędkości SPEED LUX

System SPEED LUX



CODE

20-0000-23



100 W



80-100 m
(150-170 m)



230 mm



30 kg



820x820x120 mm



240 V AC, 12 V DC



● ○



CREE Super Brightwith 8000 mcd
i 25000 mcd (żywność do 100 000 h)

Sygnalizacja tymczasowa

Temporary signalisation



CODE

20-0200-90
20-3200-90
20-0200-92



ø200 mm
ø300 mm
ø200 mm z minutnikiem / with countdown



KARTON/BOX



55 kg



240x500x800 mm



Tak/Yes



12 V



90 Ah - 7 dni/ days



Tak/Yes



-15°C – +85°C



1-99 sek.
5-495 sek.



automatyczne ustawianie intensywności świecenia
automatic regulation of light intensity



20-0200-92



Tablica kierunkowa 60x60

LED directional panel 60x60

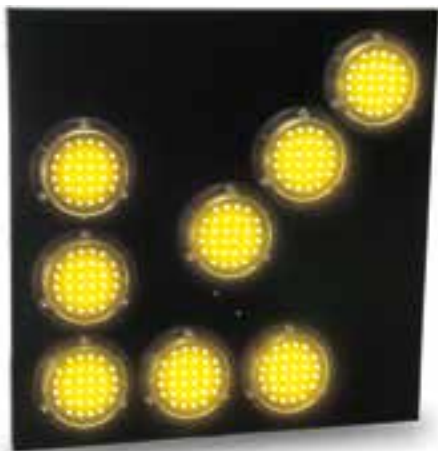

CODE

20-0060-10



6,5 kg



ø100 - 600x600x130 mm



20h/250h/520h



ø200 EN 12352
klasa L*H

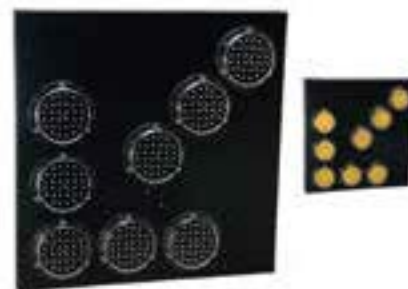

Tablica kierunkowa 70x70

LED directional panel 70x60



CODE

20-0070-20



8,2 kg



ø100 - 700x700x130 mm



35h/65h/130h



ø100 EN 12352
klasa L*H



Tablica kierunkowa 90x90

LED directional panel 90x90



CODE

20-0090-10



15 kg



ø200 - 900x900x130 mm



20h/250h/520h



ø200 EN 12352
klasa L*H



Tablica kierunkowa 105x105

LED directional panel 105x105

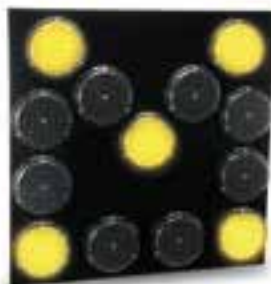

CODE

20-0105-20



35h/65h/130h



20 kg



ø200 - 1050x1050x130 mm



ø100 EN 12352
klasa L*H



Aktywny słupek U-5b 600, solar

Warning bollard U-5b 600, solar



CODE

11-6005-02



18-20 Ah 12 V



3-5 dni/days
70-100 h



18 kg



Tak/Yes



40 W



1300x (400x300) x ø600 mm



60Ah/90Ah/180Ah



Tak/Yes



NAJEZDNIOWE ELEMENTY ODBLASKOWE

ROAD STUDS

PL Najezdniowe elementy odblaskowe, to produkty, które wyróżniają się dzięki wyjątkowej, opatentowanej technologii.

Różnorodność tych elementów pozwala na dostosowanie ich funkcji do konkretnego miejsca i panujących tam warunków atmosferycznych.

Wszystkie produkty z tej kategorii wymagają montażu w nawierzchni drogi przy użyciu specjalistycznego sprzętu do nawiercania wpustów. W powstały otwór wlewa się dedykowany do tego celu klej i umieszcza element odblaskowy.

Odblaski dzielimy na jedno lub dwukolorowe. Niektóre działają tylko na zasadzie błysku wywołanego odbiciem światła od nadjeżdżającego samochodu. Inne mają panel solarny, który zasila je w energię potrzebną do emitowania błysku.

Szklane elementy odblaskowe są dodatkową grupą w tej kategorii. Różnią się między sobą średnicą. Wszystkie są wykonane z bardzo wytrzymałego szkła hartowanego. Są one odporne nawet na kontakt z pługiem śnieżnym. Wytrzymują nacisk punktowy do 80 ton. Nie wymagają konserwacji. W tej grupie tylko element LUX 2, którego trzpień jest w gumowej osłonie, nie wymaga użycia kleju w czasie montażu.

ENG Road studs are products that stand out thanks to a unique, patented technology.

The variety of these elements allows you to adjust their functions to a specific place and weather conditions there.

All products in this category require installation on the road surface using specialized equipment for drilling the grooves. A dedicated adhesive is poured into the resulting hole and a reflective element is placed.

We divide reflectors into one or two colors. Some work only on the basis of flash caused by light reflected from an oncoming car, while others have a solar panel that supplies them with the energy needed to emit the flash.

Glass reflective elements are an additional group in this category. They differ in diameter. They are all made of very durable tempered glass. They are even resistant to contact with a snow plow. They withstand a point pressure of up to 80 tons. They do not require maintenance. In this group, only the LUX 2 element, the pin of which is covered with a rubber cover, does not require the use of glue during assembly.



Najezdniowy element odblaskowy, aluminiowy na trzpieniu

Solid aluminium road stud



CODE



0,30 kg



103x103x20 mm



ø20x45 mm



15 t



20 mm

Najezdniowy aktywny element odblaskowy, aluminiowy na trzpieniu

Solid aluminium road stud, solar



CODE



0,35 kg



125x105x25 mm



ø22x45 mm



20 t



20 mm

Najezdniowy element odblaskowy, aluminiowy na trzpieniu MINI PEO

Solid aluminium road stud MINI PEO



CODE



0,15 kg



85x55x53 mm



ø18x50 mm



13 t



16 mm

Najezdniowy aktywny element odblaskowy, wpuszczany, solar

Solid aluminium road stud, solar



CODE



0,98 kg



ø126x56,5 mm

15-0020- 01

15-0021- 01

230V 15-0030- 01



Ni-MH 1,2V 1200 mAh



40 t



6,5 mm



Szkłany element odblaskowy, 50 mm, LUX 1

Solid glass road stud, 50 mm, LUX 1



CODE    
15-0050- 01 02 0,12 kg ø50 mm

 ø35 mm

 80 t





 11 mm



Szkłany element odblaskowy, 50 mm, LUX 2

Solid glass road stud, 50 mm, LUX 2



CODE    
15-0050- 03 04 0,17 kg ø50 mm

 ø45 mm

 80 t

 11 mm

Szkłany element odblaskowy, 100 mm, LUX 3

Solid glass road stud, 100 mm, LUX 3



CODE    
15-0100- 01 02 0,54 kg ø100 mm

 ø26 mm

 80 t

 18,5 mm



Szklany element odblaskowy, 50 mm, LUX 5

Solid glass road stud, 50 mm, LUX 5



CODE   
15-0050- 05 0,06 kg ø100 mm

ø26 mm

80 t

18,5 mm



Kocie oczka PVC

„Cat's eyes” PVC



CODE      
15-0050- 01 06 07 09 0,10 kg 90x100x15 mm



Ćwiki chodnikowe

Paving surfaces

CODE

15-0025-00

15-0100-00



0,02 kg

0,21 kg



ø25 mm H: 23 mm

ø100 mm H: 150 mm



15-0100-00
Trzpień ø20 mm



15-0025-00
Trzpień ø8 mm

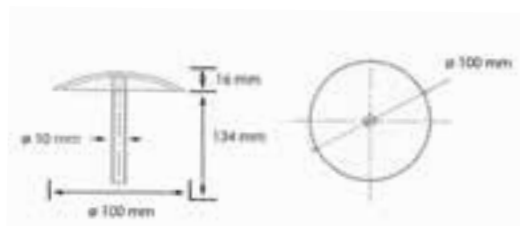



LUSTRA DROGOWE

ROAD MIRRORS

PL **Lustra drogowe wykonane z aluminiowego akrylu charakteryzują się wysoką odpornością na zniszczenia oraz warunki atmosferyczne. W zależności od wymiaru sprawdzają się w różnych miejscach na drodze, magazynie, hali produkcyjnej czy sklepie.**

Lustra występują w różnych wielkościach i wyposażone są w detale, które określają ich przeznaczenie.

Wspólną cechą charakterystyczną dla wszystkich lusterek z tej kategorii jest wypukła tafla, która zapewnia szeroki kąt widzenia pod warunkiem odpowiedniego ustawienia lustra. Lustra uniwersalne, drogowe i przemysłowe posiadają uchwyt do zamontowania na słupku ocynkowanym. Można je również przymocować do ściany używając do tego specjalnego uchwyty.

Lustra wewnętrzne, które sprawdzają się w sklepach mają fabryczny wysięgnik o długości około 33 cm. Inną grupą lusterek przeznaczonych do pomieszczeń są lustra kopułowe, które zapewniają widoczność nawet 360°. Przytwierdza się je do sufitów lub zawieszają na dedykowanych do nich łańcuszkach.

Najbardziej wytrzymałymi lustrami są stalowe w biało-czerwonej ramie. Poddawane są testom, które udowadniają ich wytrzymałość nawet na strzały z lekkiej broni. Ten rodzaj lusterek występuje w 4 rozmiarach w formie koła i prostokąta, a ich staranne wykonanie i wypukła tafla zapewniają doskonałą widoczność.

Osobną podgrupą są lustra rewizyjne, służące do sprawdzania pojazdów i maszyn w miejscach, w których jest to utrudnione.

ENG **Road mirrors made of aluminum acrylic are highly resistant to damage and weather conditions. Depending on the size, they will work in various places on the road, in warehouses, production halls or stores.**

Mirrors come in various sizes and are equipped with details that define their purpose.

A common feature for all mirrors in this category is a convex sheet that provides a wide viewing angle, provided the mirror is properly positioned.

Universal, road and industrial mirrors have a handle to be mounted on a galvanized post. They can also be attached to the wall using a special holder.

Internal mirrors that work well in shops have a factory extension arm that is about 33 cm long. Another group of mirrors intended for rooms are dome mirrors, which provide visibility of up to 360°. They are attached to ceilings or hung on dedicated chains. The most durable mirrors are steel mirrors in a white and red frame. They are subjected to tests that prove their durability even against light firearms. This type of mirrors is available in 4 sizes in the form of a circle and a rectangle, and their careful workmanship and a convex surface ensure excellent visibility. Inspection mirrors are a separate subgroup for checking vehicles and machines in places where it would be physically impossible. Due to its light weight, the mirror can be easily lifted on a telescopic handle.



Lustro drogowe uniwersalne

Universal road mirror

CODE



90-9035-005	2,5 kg	ø500 – 520x520x130 mm
90-9035-006	3,2 kg	ø600 – 620x620x130 mm
90-9035-010	4,3 kg	ø700 – 720x720x150 mm
90-9035-011	5,1 kg	ø800 – 820x820x190 mm
90-9035-013	6,3 kg	ø900 – 910x910x190 mm



Lustro drogowe U-18a

Road mirror U-18a

CODE



90-9035-074	3 kg	ø500 – 630x630x150 mm
90-9035-026	3,7 kg	ø600 – 730x730x170 mm
90-9035-075	5,5 kg	ø700 – 830x830x180 mm
90-9035-027	6 kg	ø800 – 930x930x180 mm
90-9035-900	8 kg	ø900 – 1030x1030x190 mm
90-9035-039	10 kg	ø1000 – 1130x1130x190 mm



Lustro drogowe U-18b

Road mirror U-18b

CODE



90-9035-030	4 kg	600x400 – 760x560x150 mm
90-9035-040	5,5 kg	800x600 – 940x740x150 mm
90-9035-041	8 kg	1000x800 – 1140x940x150 mm



Lustro przemysłowe

Industrial mirror



90-9021-006

CODE

- 90-9035-45
- 90-9035-050
- 90-9035-051



- 3,7 kg
- 6 kg
- 10 kg



- ø600 – 730x730x170 mm
- ø800 – 930x930x180 mm
- ø1000 – 1130x1130x190 mm



CODE

- 90-9035-044
- 90-9035-043
- 90-9035-042



- 4 kg
- 5,5 kg
- 8 kg



- 600x400 – 760x560x150 mm
- 800x600 – 940x740x150 mm
- 1000x800 – 1140x940x150 mm

Lustro stalowe ABS

Stainless steel mirror



CODE

- 90-9035-60
- 90-9035-80



- 8 kg
- 11,5 kg



- ø600 mm
- ø800 mm



CODE

- 90-9035-46
- 90-9035-68



- 9 kg
- 12,5 kg



- 450x600 mm
- 600 x 800 mm

Lustro wewnętrzne

Indoor mirror

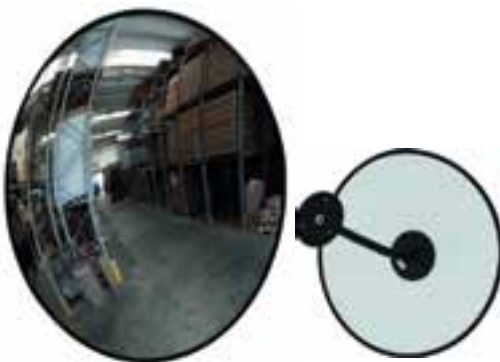

CODE

- 90-9035-021
- 90-9035-022
- 90-9035-023
- 90-9035-024
- 90-9035-046
- 90-9035-047



- 0,6 kg
- 0,95 kg
- 1,3 kg
- 1,7 kg
- 2,2 kg
- 4,3 kg



- ø300 – 310x310x40 mm
- ø400 – 410x410x50 mm
- ø500 – 510x510x60 mm
- ø600 – 610x610x60 mm
- ø700 – 710x710x60 mm
- ø900 – 910x910x80 mm



CODE

- 90-9035-048
- 90-9035-049



- 1,62 kg
- 2,35 kg



- 600x400 – 630x430x80 mm
- 60 800x600 – 810x610x60 mm





Lustro wewnętrzne 1/2 i 1/4 kopuły

Indoor mirror 1/2 and 1/4



CODE

90-9012-007	0,35 kg	1/2 ø600 – 600x300x200 mm
90-9012-008	0,5 kg	1/2 ø700 – 700x350x260 mm
90-9012-009	0,8 kg	1/2 ø800 – 800x400x280 mm
90-9012-010	0,85 kg	1/2 ø900 – 900x450x340 mm
90-9012-011	1,2 kg	1/2 ø1000 – 1000x500x400 mm



CODE

90-9012-012	0,2 kg	1/4 ø60 – 300x300x200 mm
90-9012-013	0,25kg	1/4 ø70 – 350x350x260 mm
90-9012-014	0,4 kg	1/4 ø80 – 400x400x280 mm
90-9012-015	0,5 kg	1/4 ø90 – 450x450x340 mm
90-9012-016	0,6 kg	1/4 ø100 – 500x500x400 mm



Lustro wewnętrzne kopuła

Surveillance mirror



90-9012-00

CODE

90-9012-002	0,7 kg	ø600 – 600x600x200 mm
90-9012-003	1 kg	ø700 – 700x700x260 mm
90-9012-004	1,6 kg	ø800 – 800x800x280 mm
90-9012-006	1,7 kg	ø900 – 900x900x340 mm
90-9012-005	2,9 kg	ø1000 – 1000x1000x380 mm



Lustro rewizyjne

Inspection mirror

CODE

90-1100-35	3 kg	ø600
------------	------	------





van berde

39-332 Tuszów Narodowy
Tuszów Narodowy 397

biuro@vanberde.com.pl
www.vanberde.com.pl

tel.: +48 17 774 56 90
fax.: +48 17 774 56 99

vb traffic

office@vbtraffic.com
www.vanberde.com.pl

tel.: +48 17 774 56 90
fax.: +48 17 774 56 99